

CV. Abadi Label

BT 01

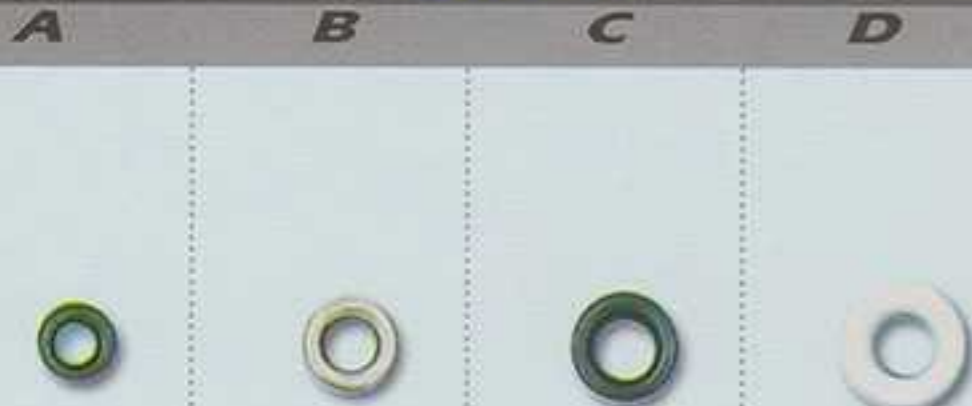

BT 02

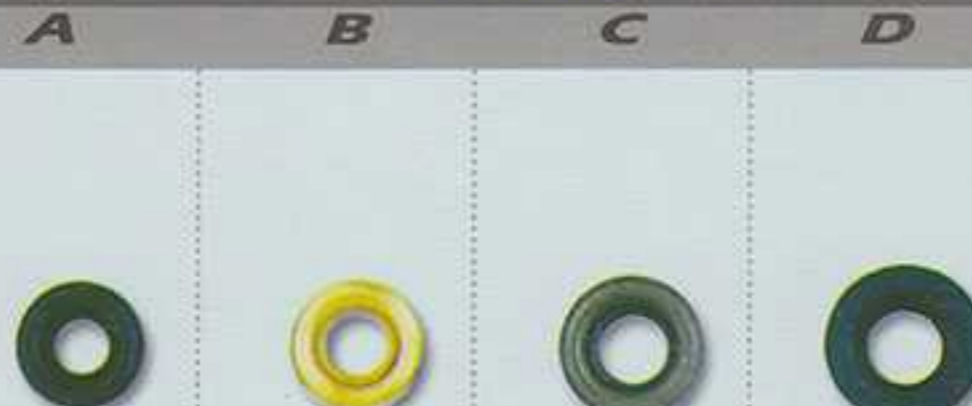

BT 03

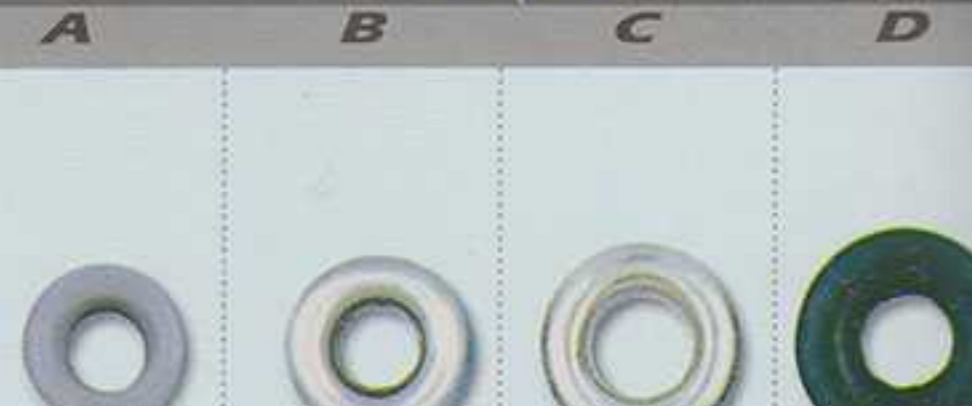

BT 04

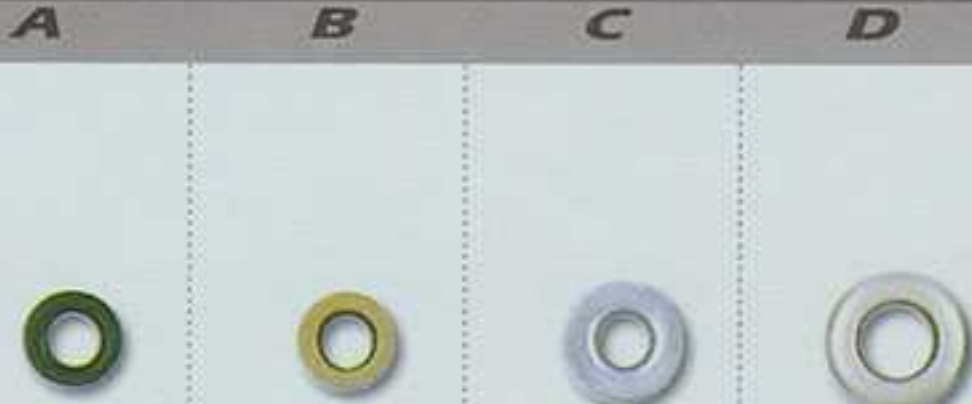

BT 05

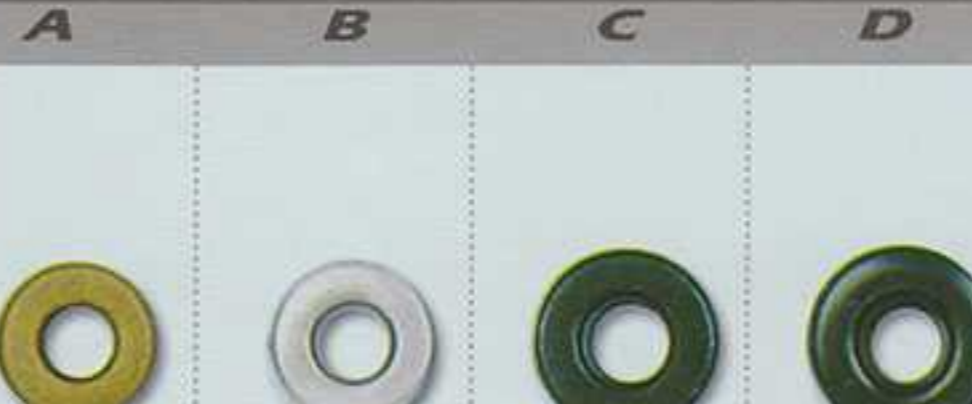

BT 06

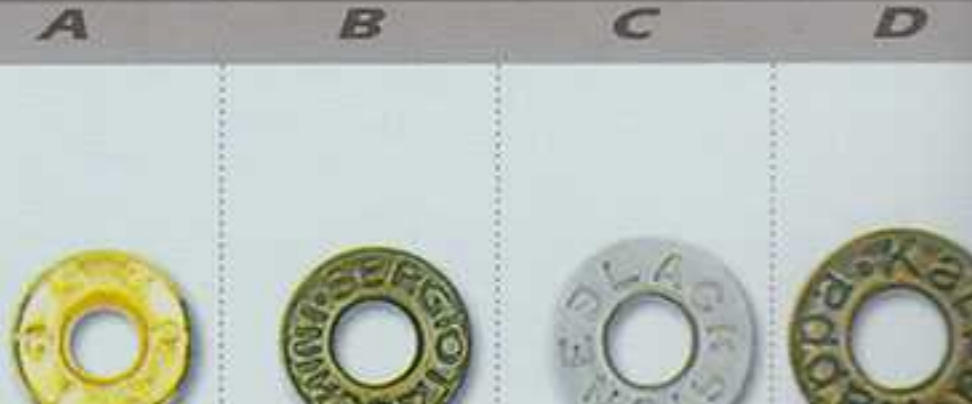

BT 07

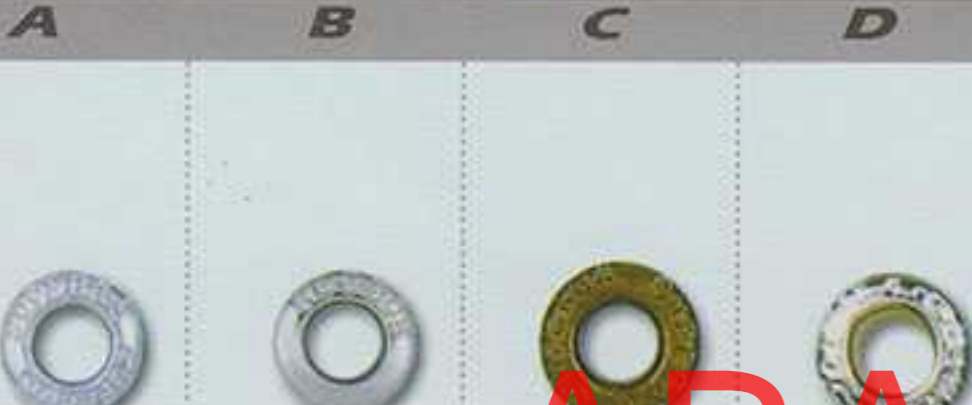

BT 08



BT 09

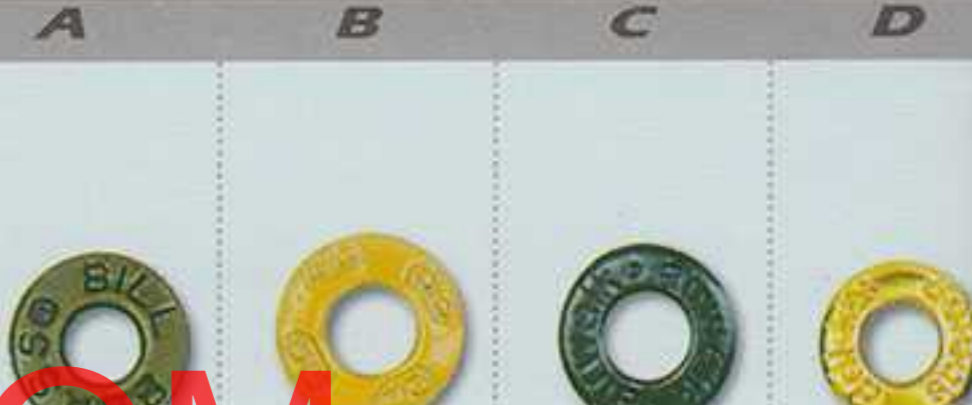

BT 10

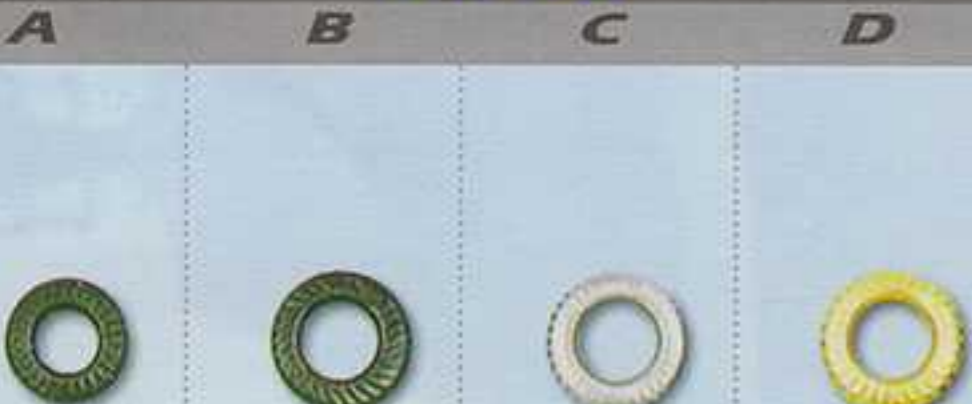

BT 11

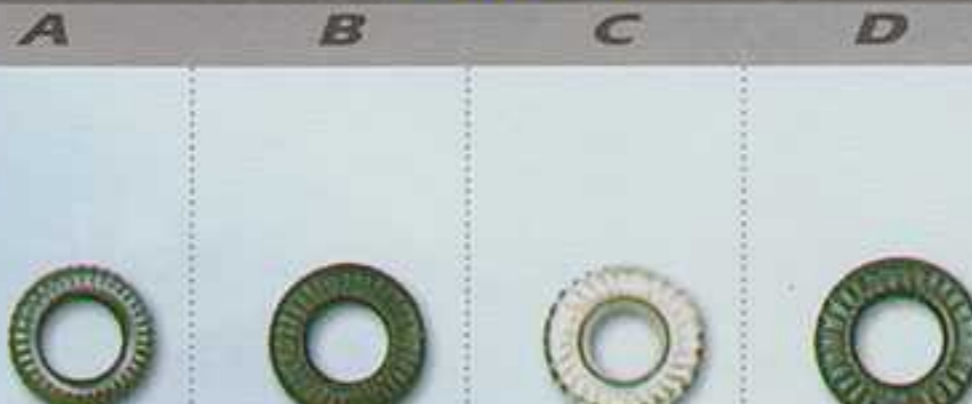

BT 12

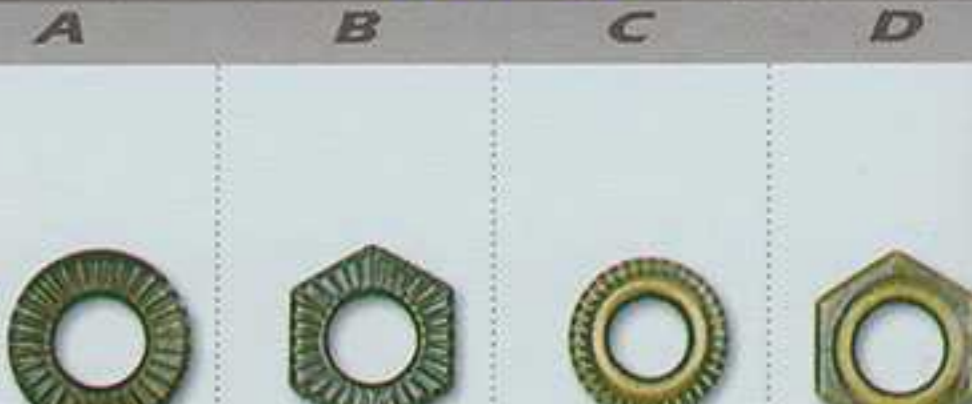

BT 13

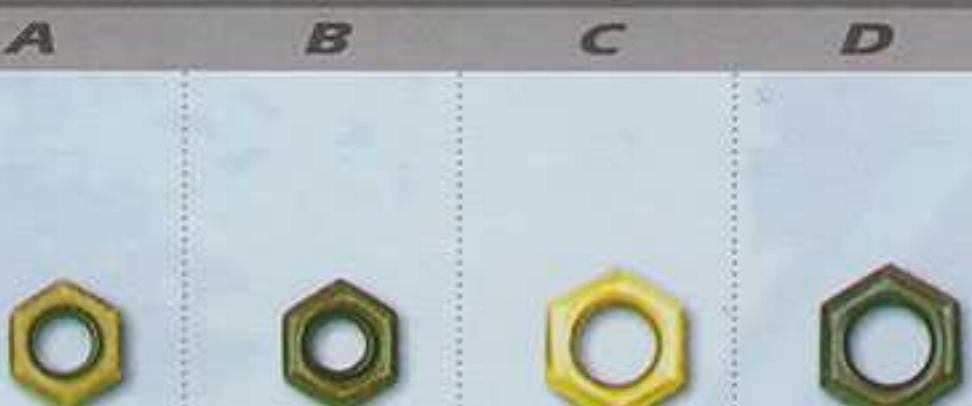

BT 14

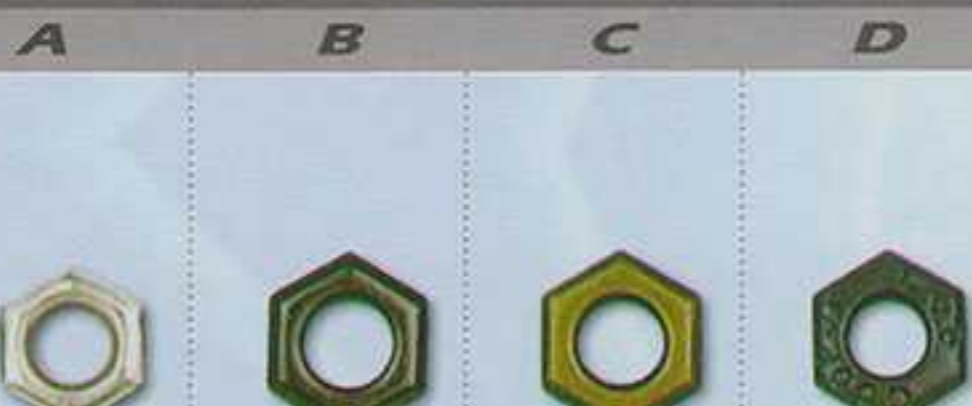

BT 15

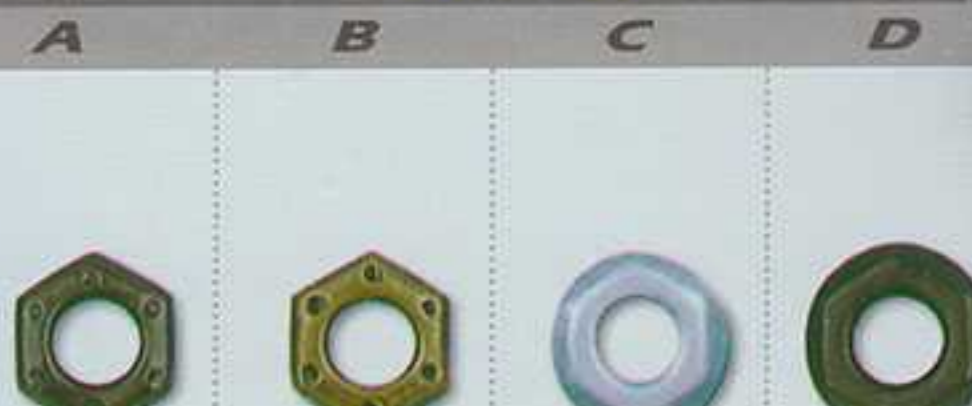

BT 16

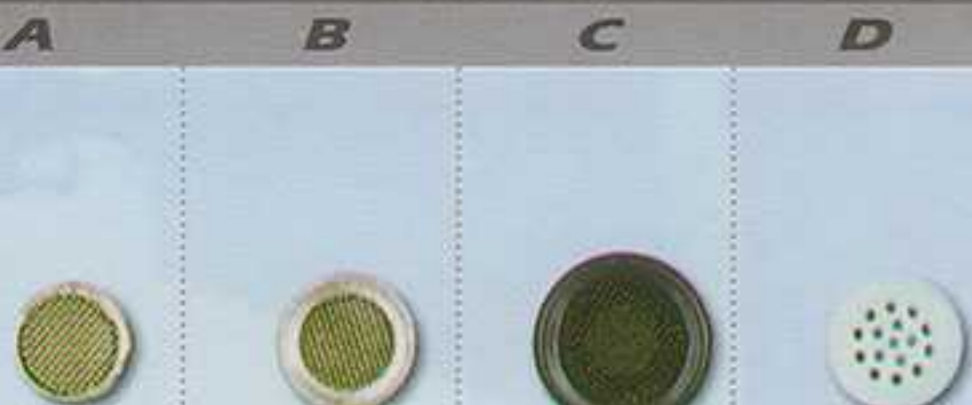

BT 17

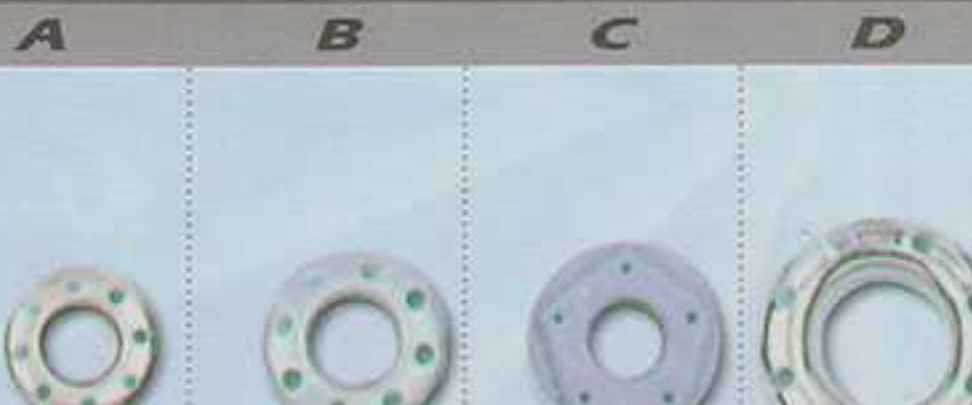

BT 18

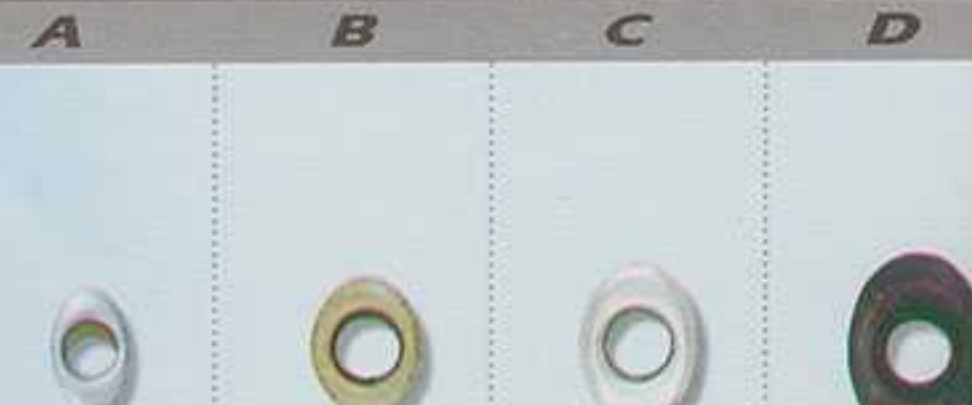

ABADILABEL.COM

CV. Abadi Label

BT 19

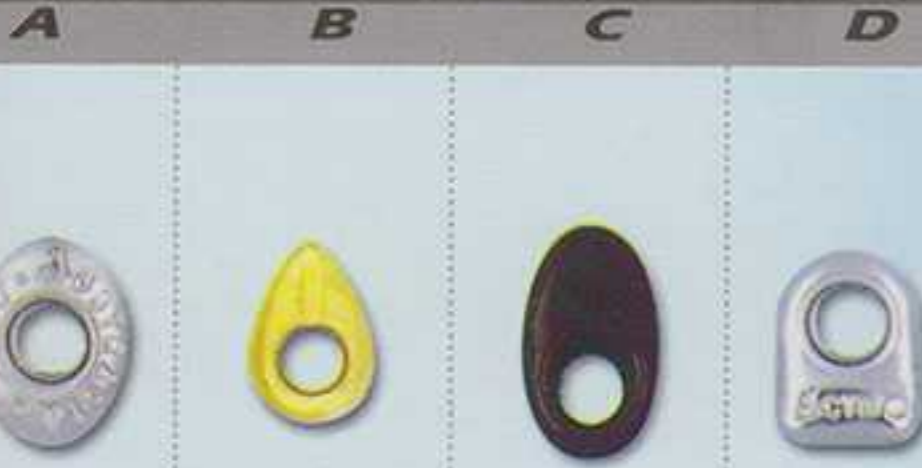

BT 20

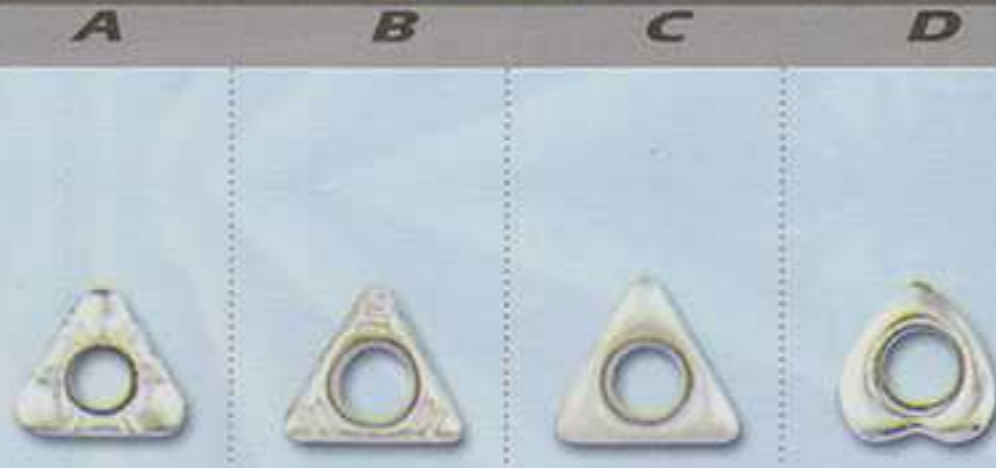

BT 21

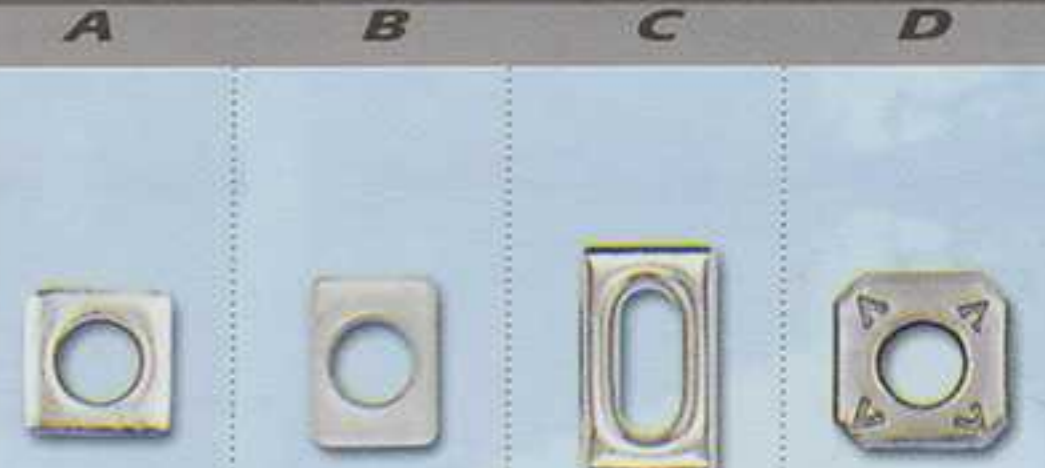

BT 22

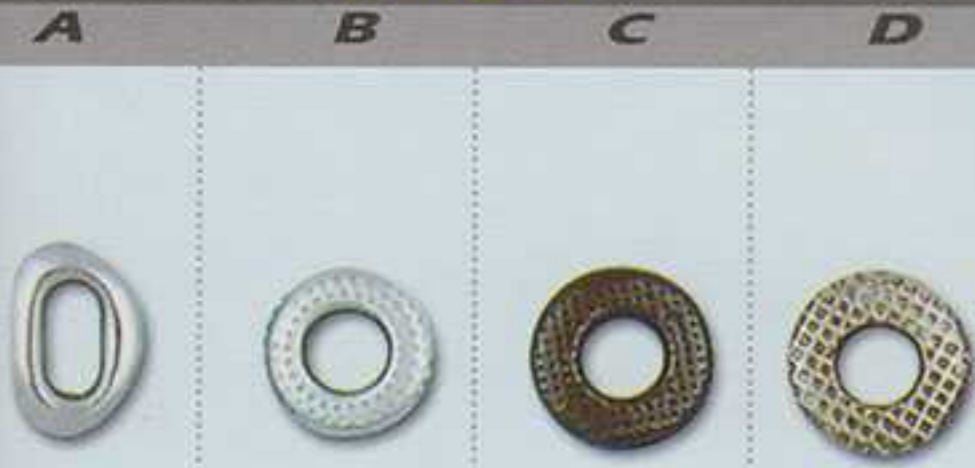

BT 23

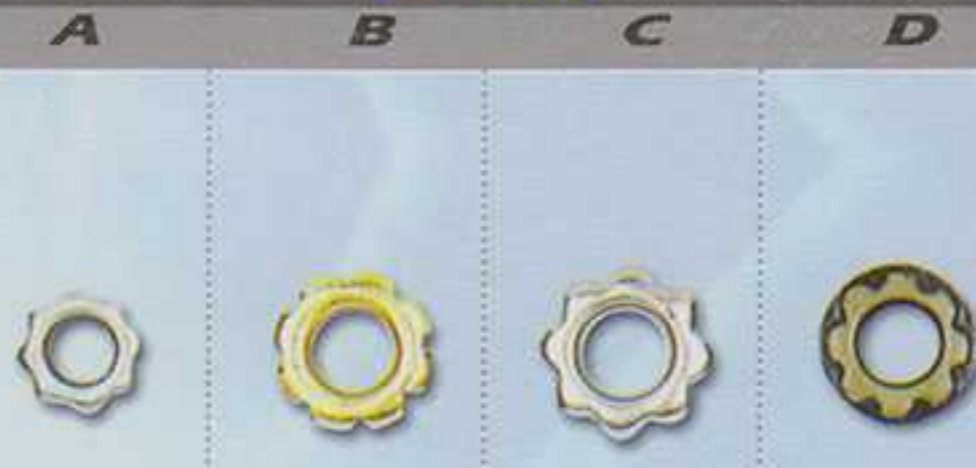

BT 24



BT 25

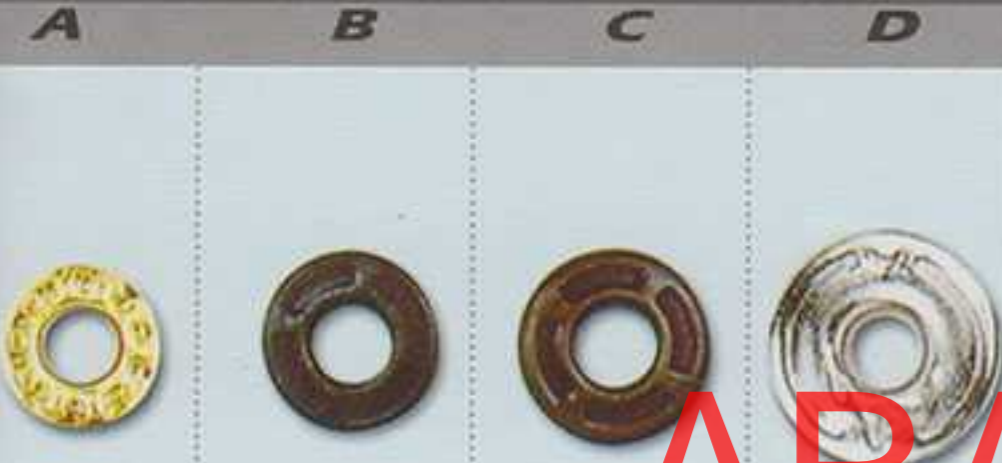

BT 26

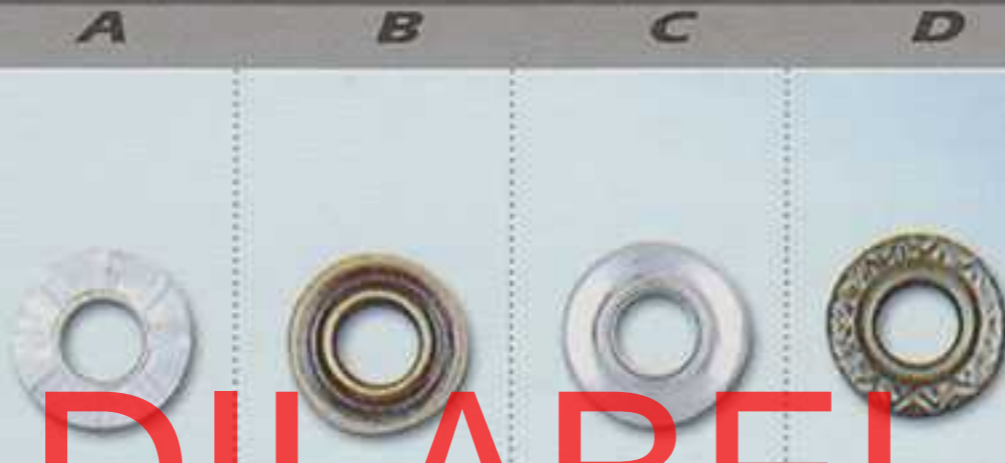

BT 27



BT 28

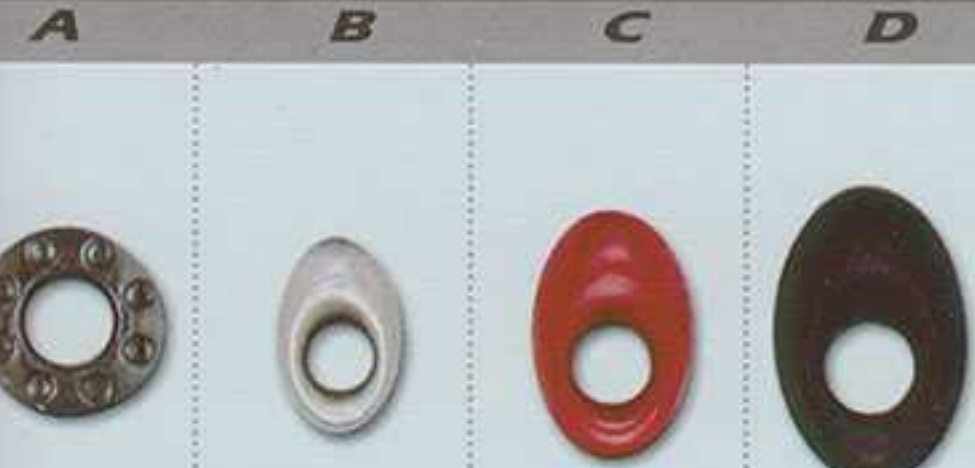

BT 29

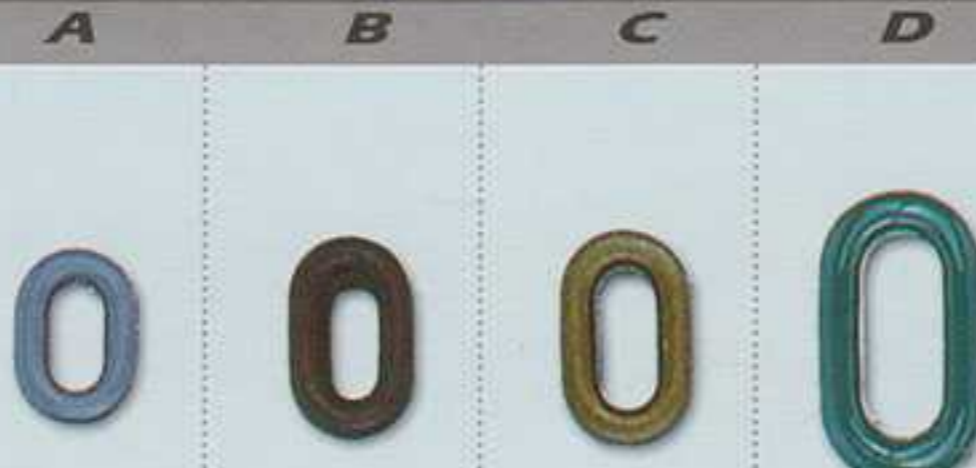

BT 30

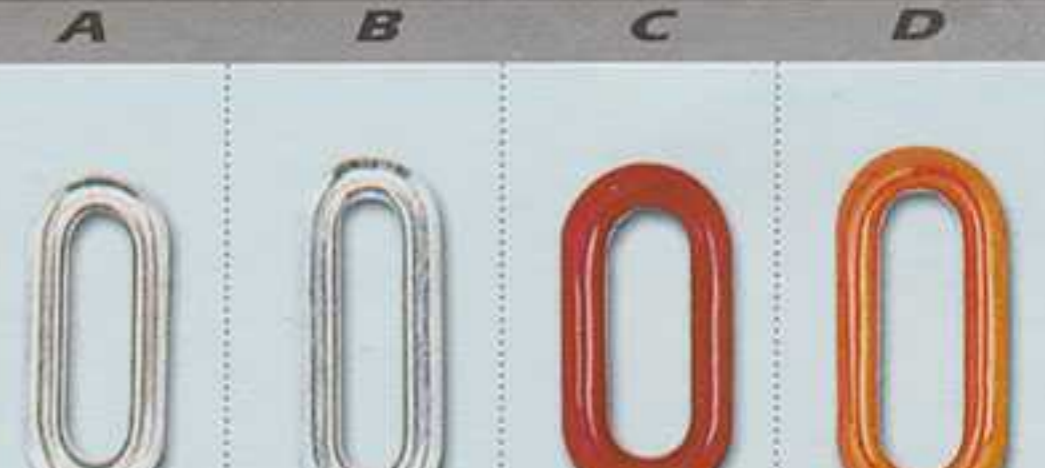

BT 31

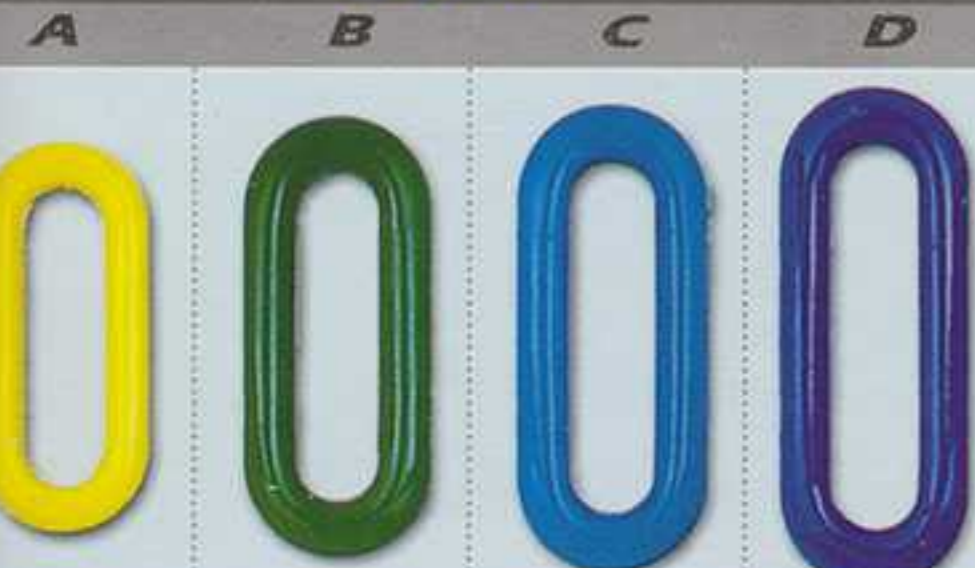

BT 32

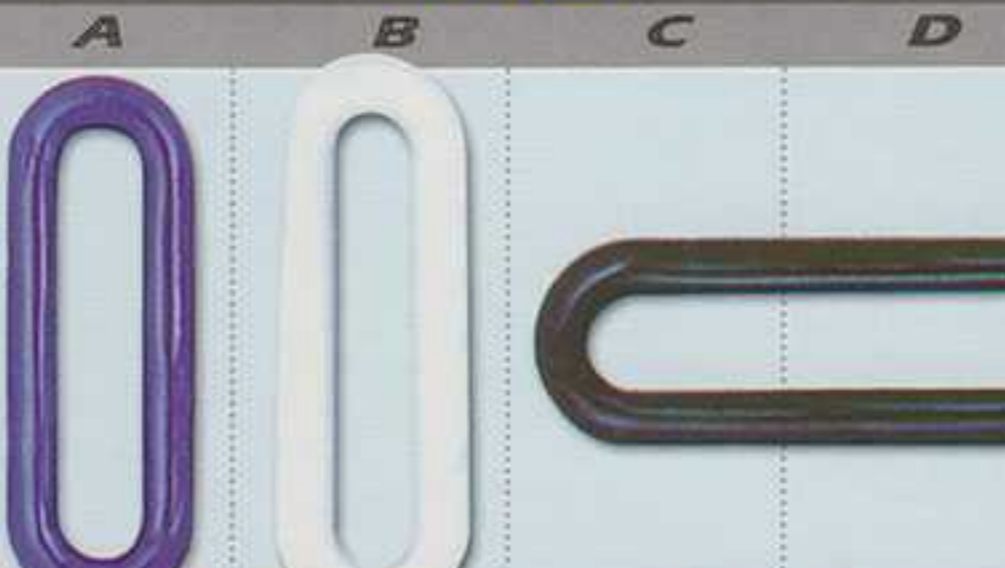

BT 33

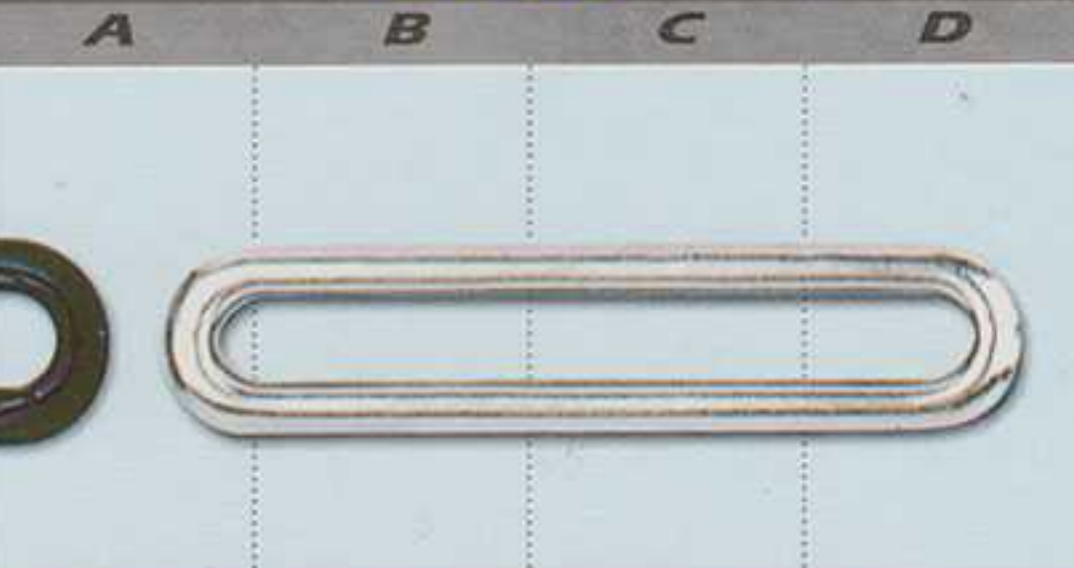

BT 34

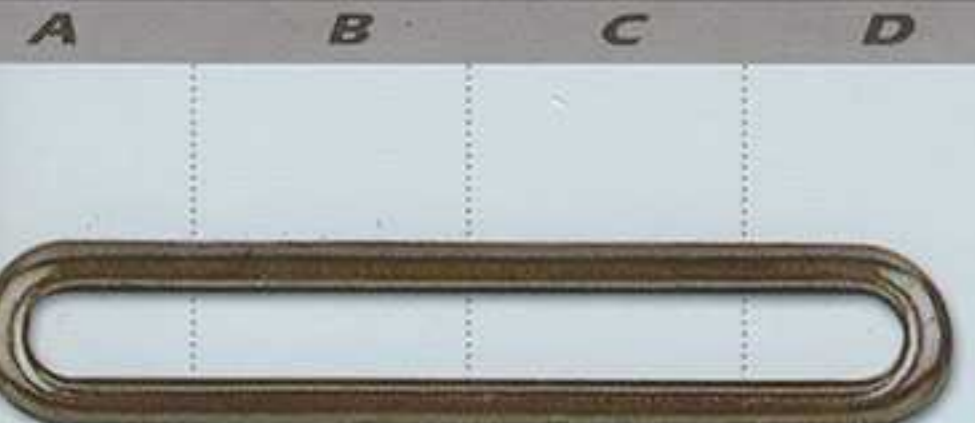

BT 35

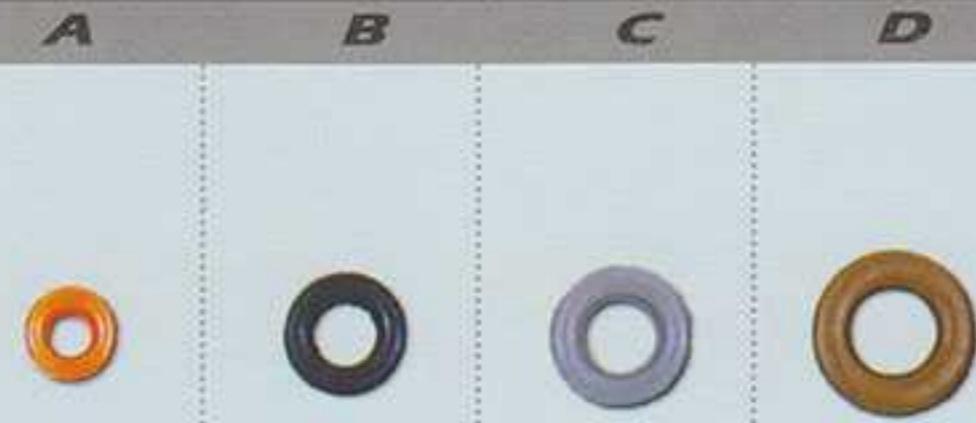

BT 36

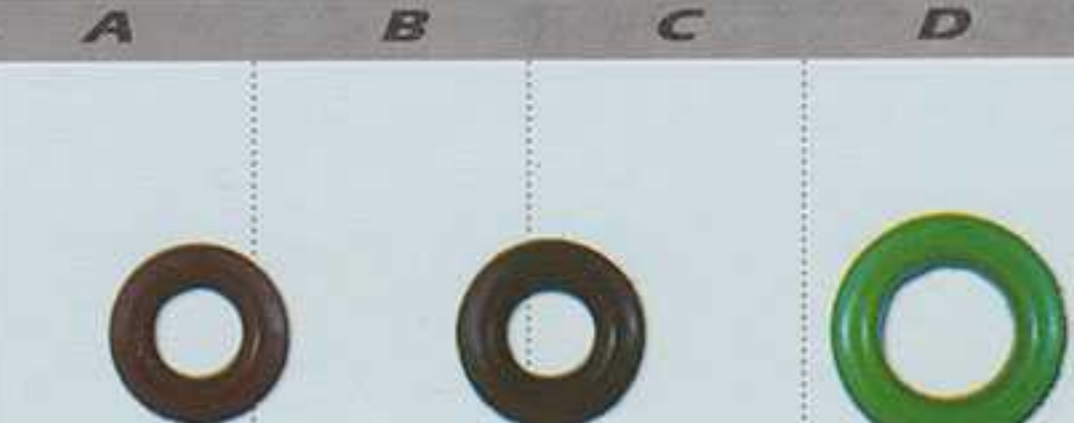

ABADILABEL.COM

CV. Abadi Label

BT 37

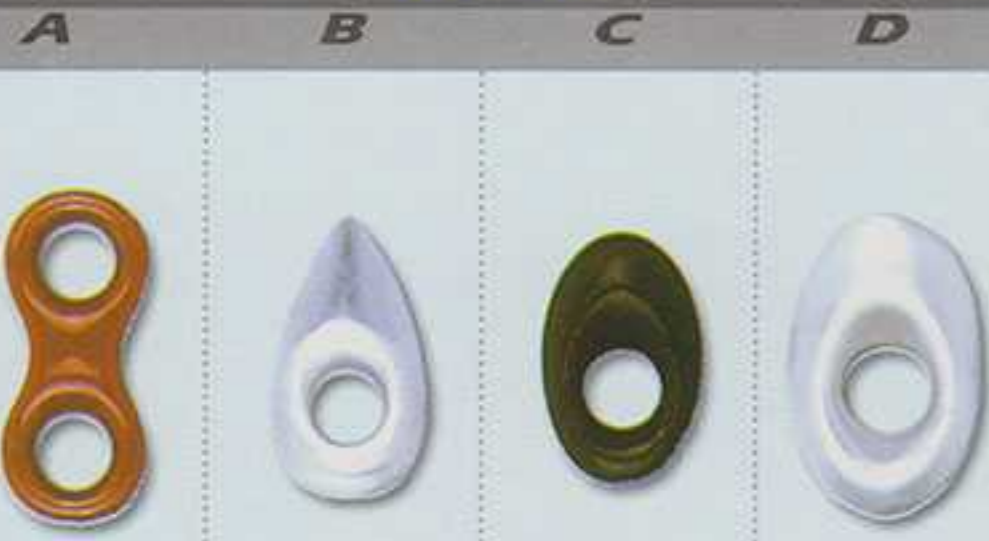

BT 38

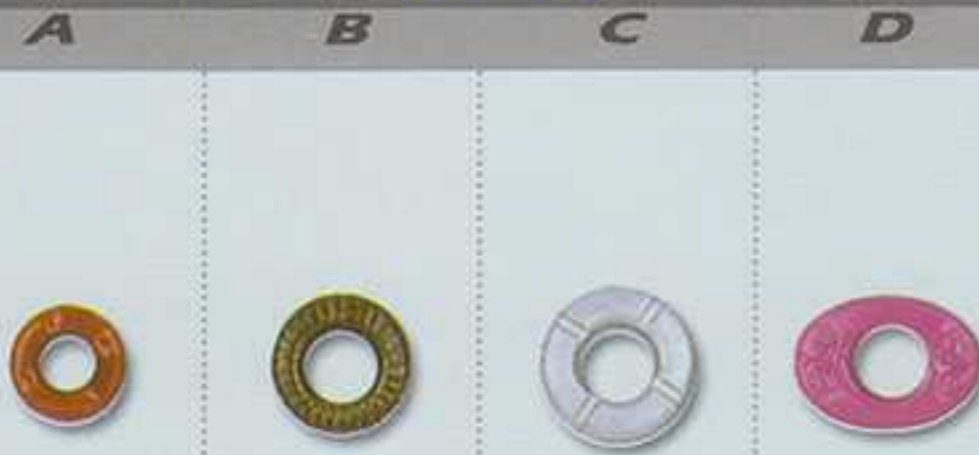

BT 39

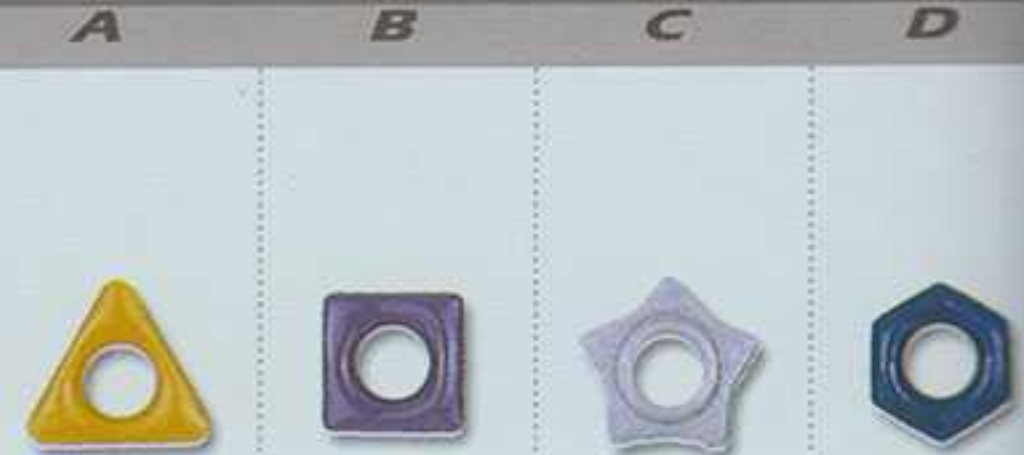

BT 40

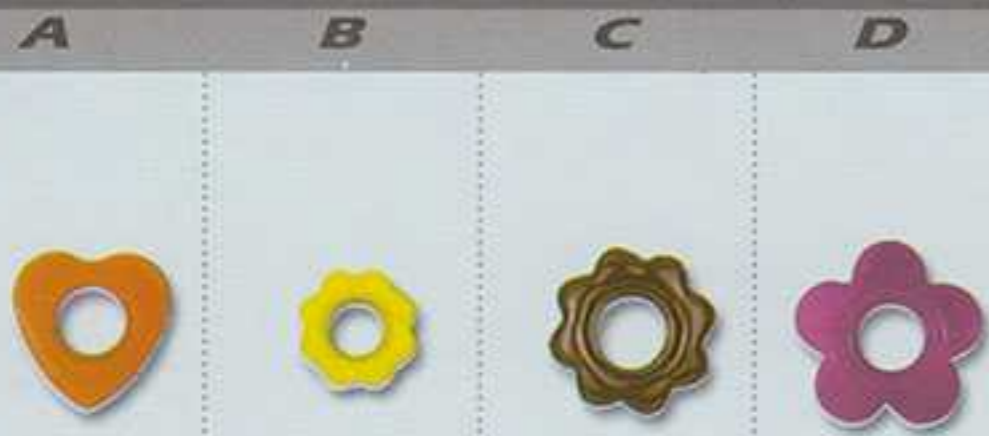

BT 41

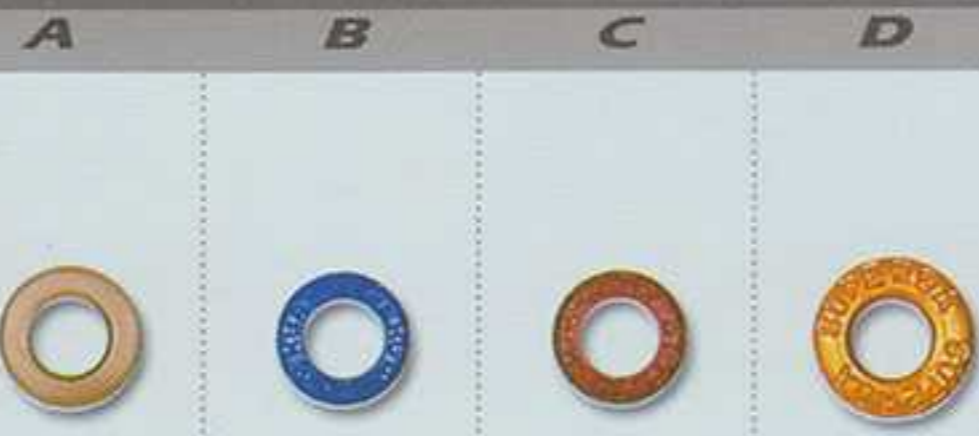

BT 42

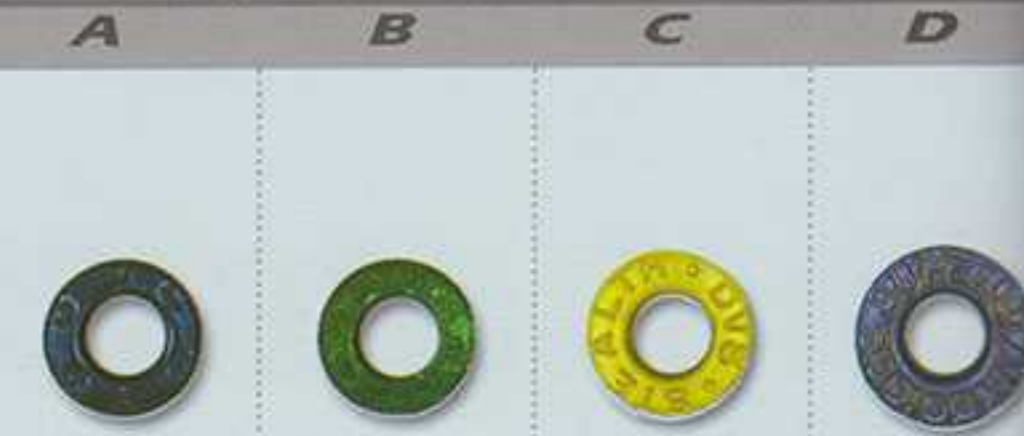

BT 43

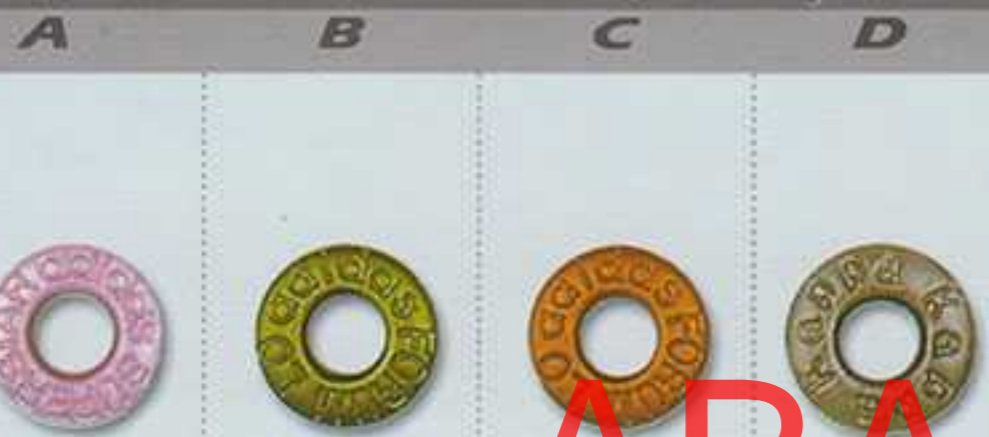

BT 44

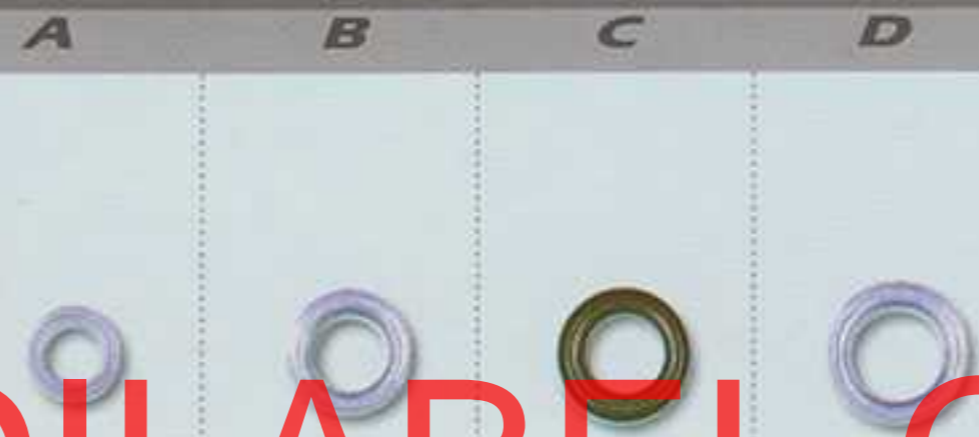

BT 45

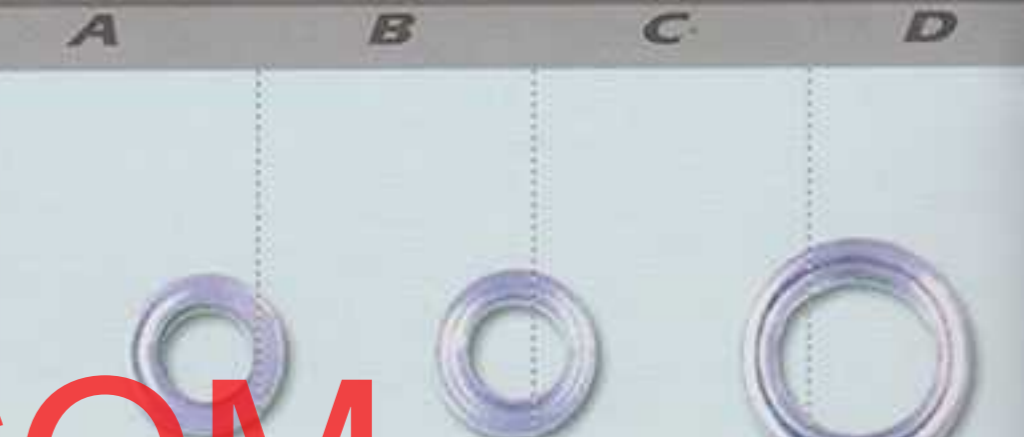

BT 46

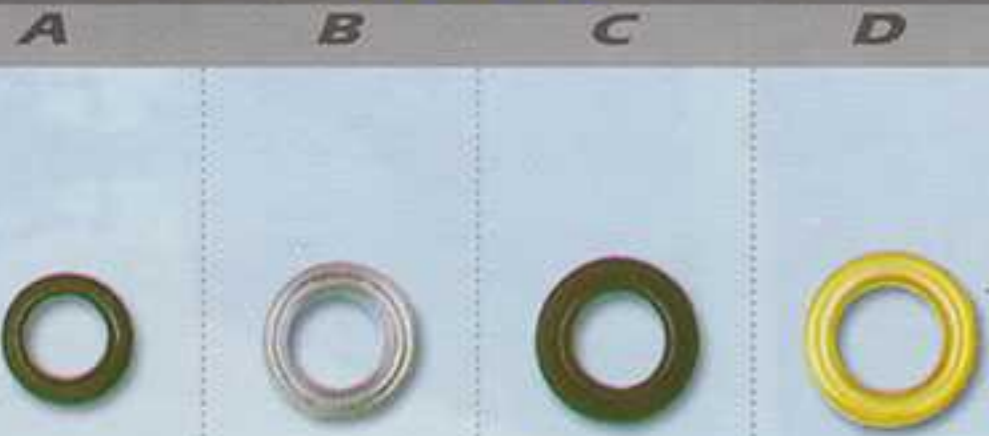

BT 47



BT 48

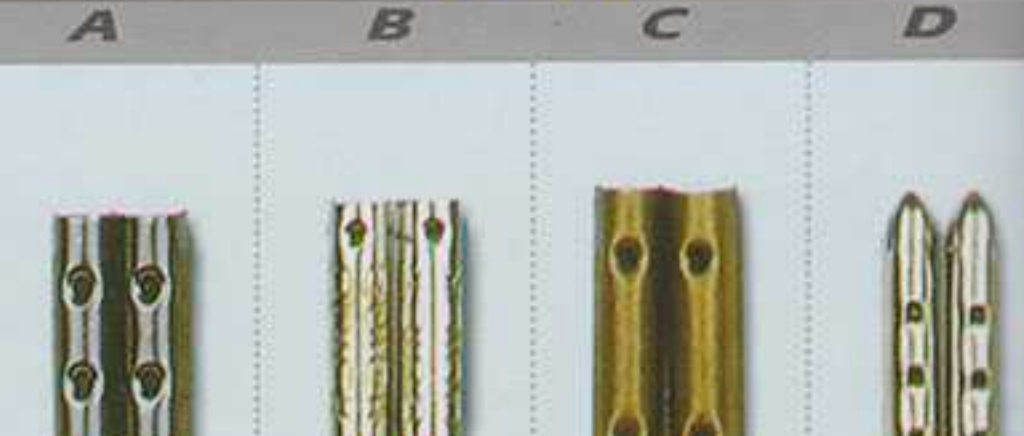

BT 49

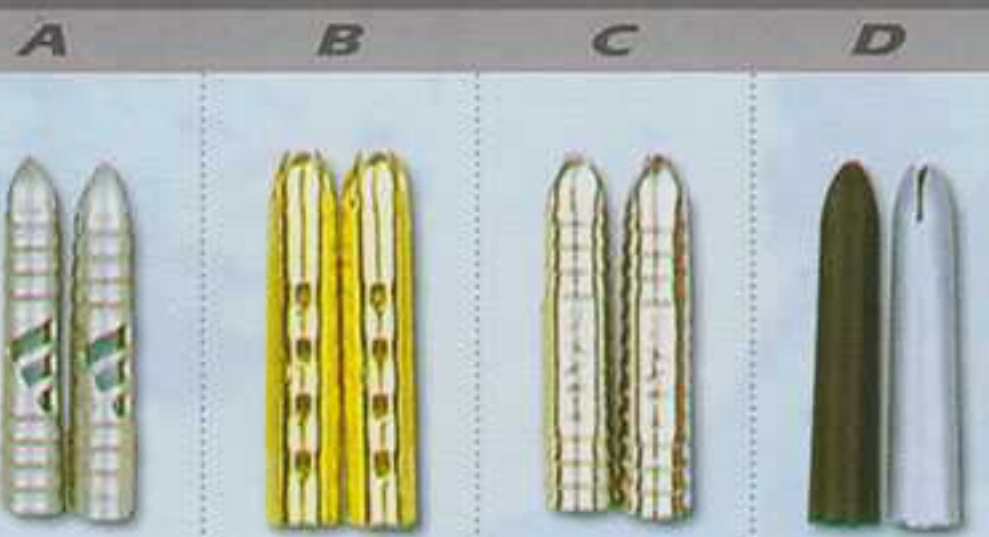

BT 50

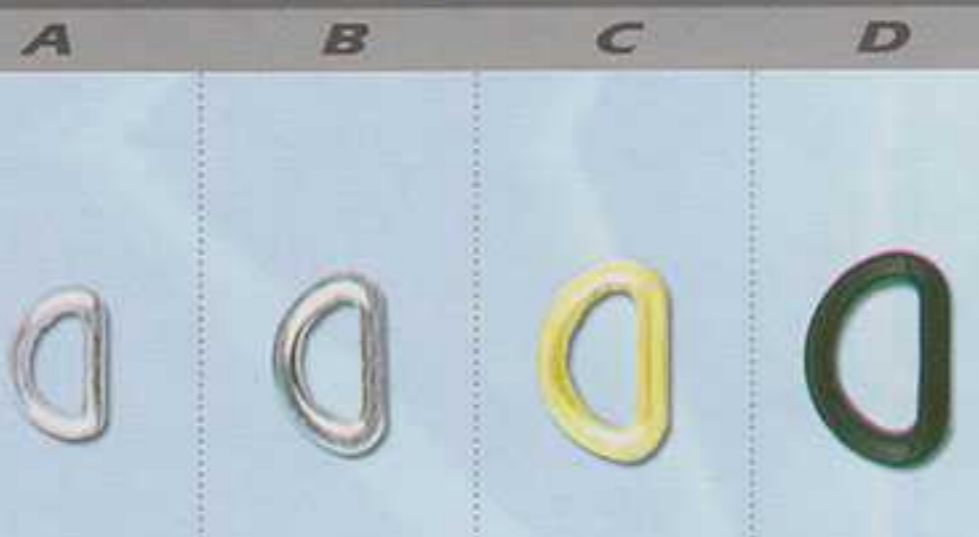

BT 51

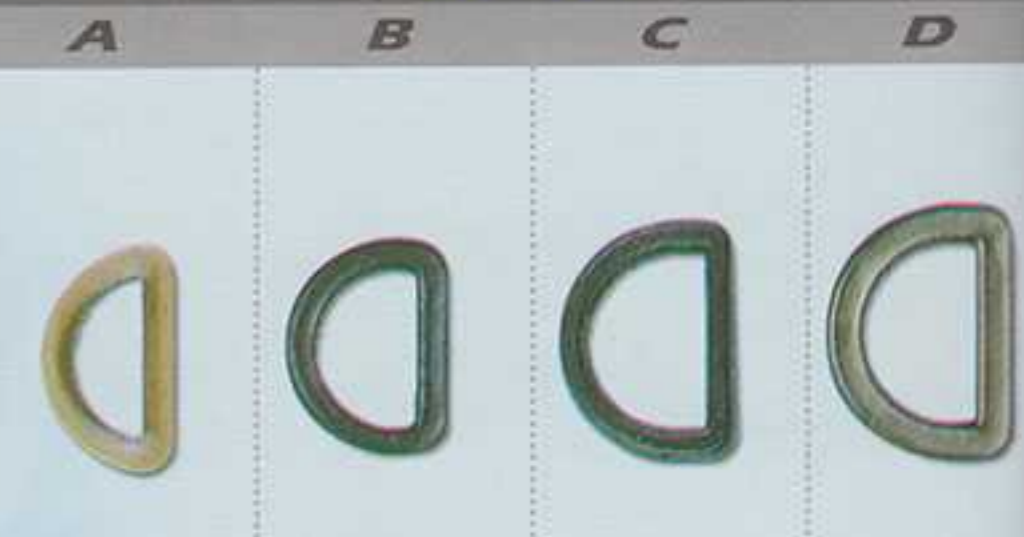

BT 52



BT 53

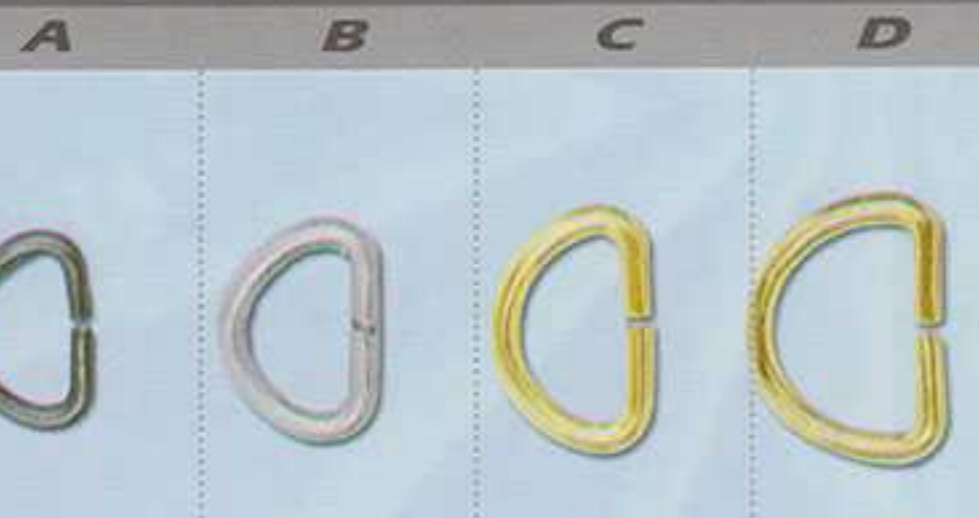

BT 54

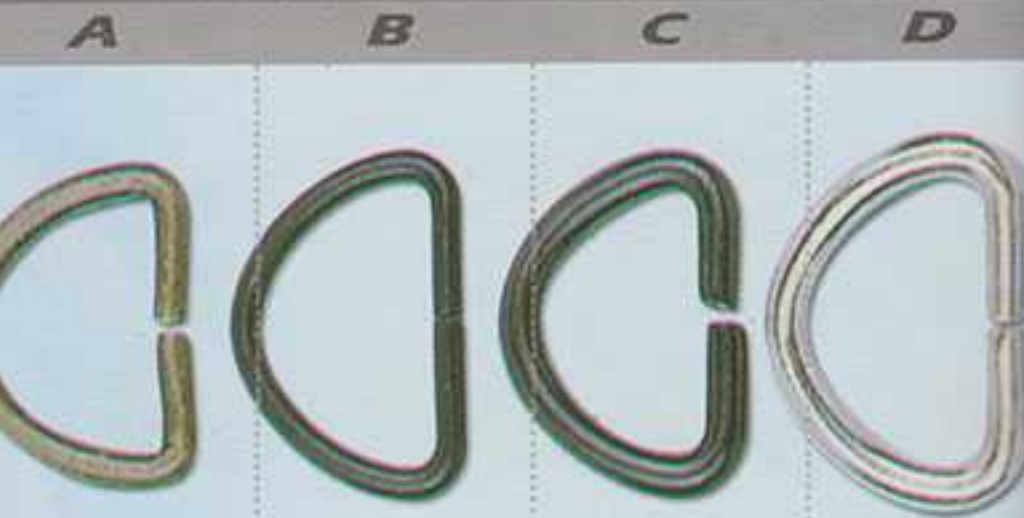

ABADILABEL.COM

CV. Abadi Label

BT 55

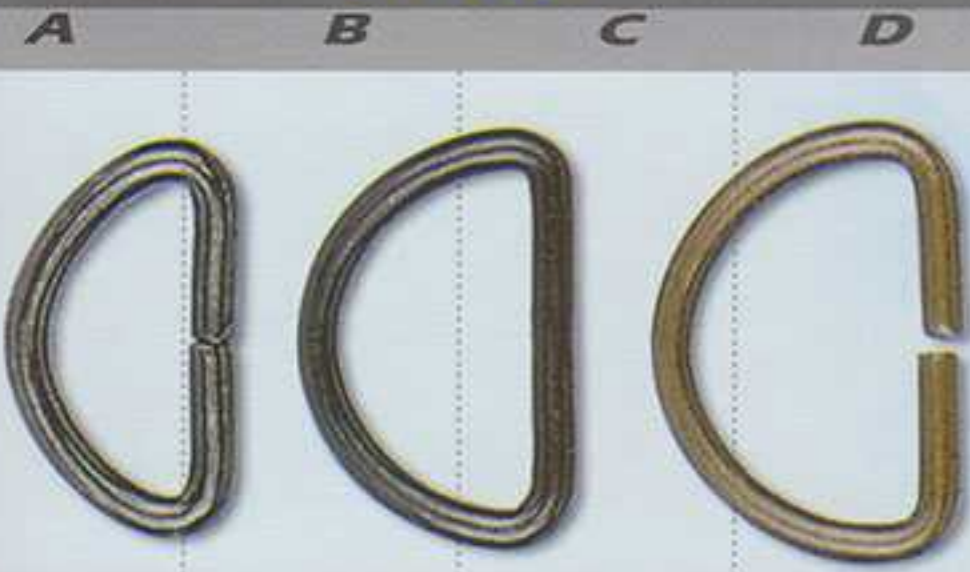

BT 56

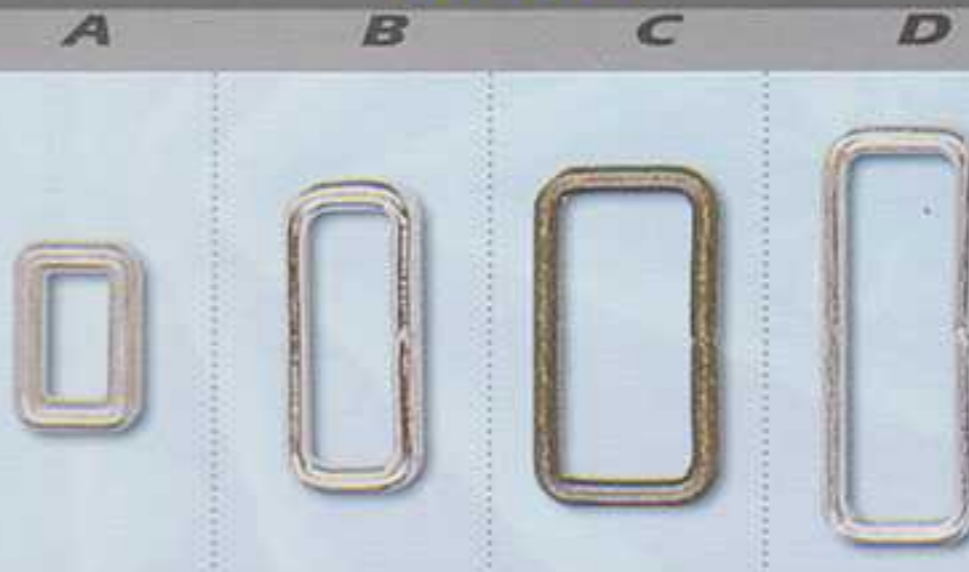

BT 57

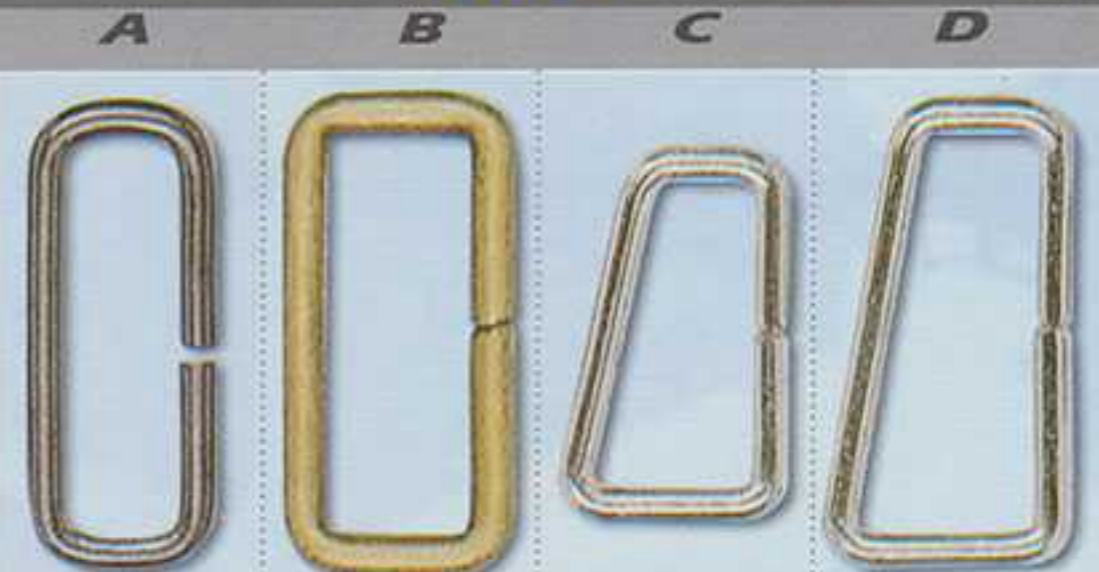

BT 58



BT 59

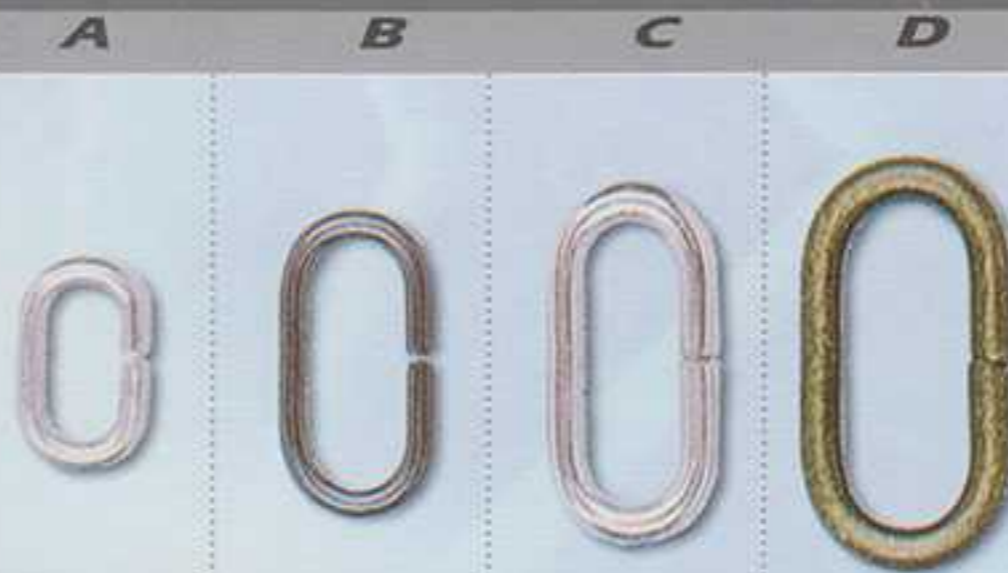

BT 60



BT 61

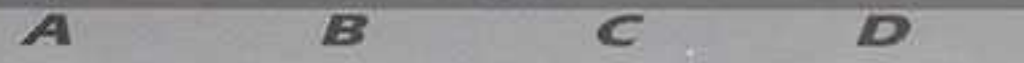

BT 62



BT 63



BT 64

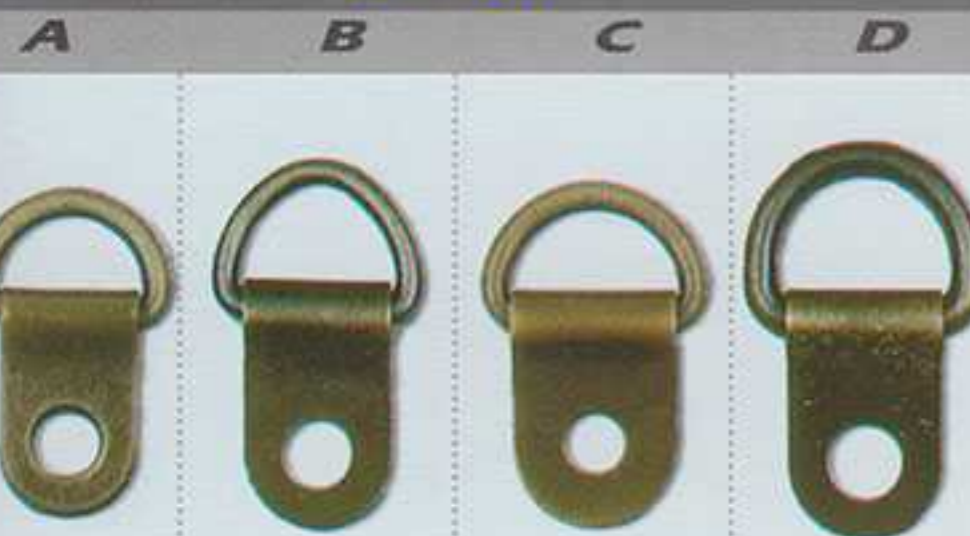

BT 65

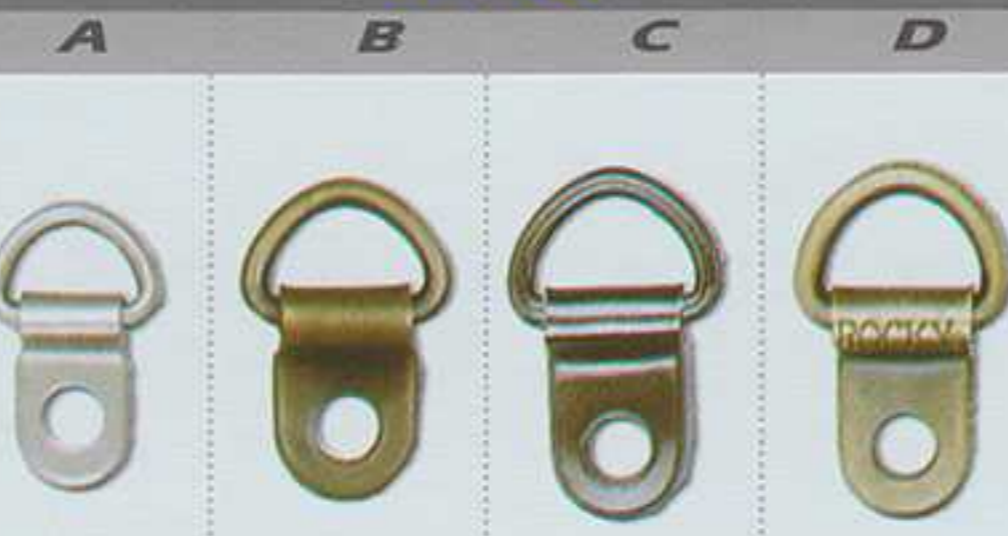

BT 66

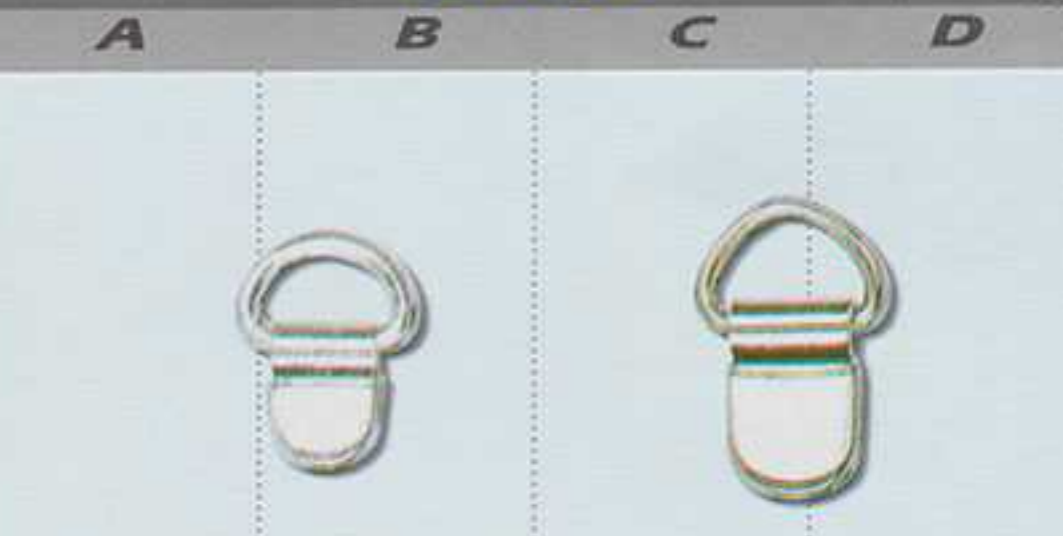

BT 67

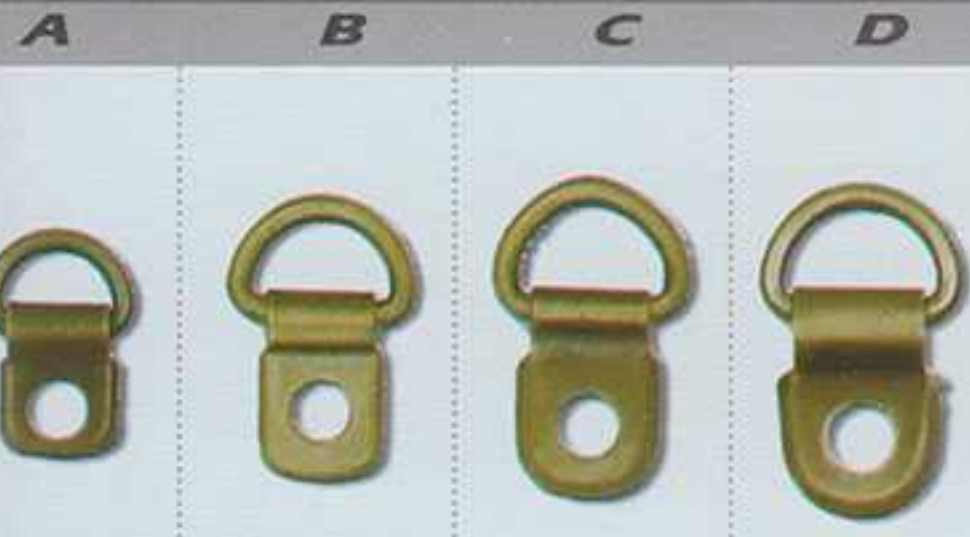

BT 68

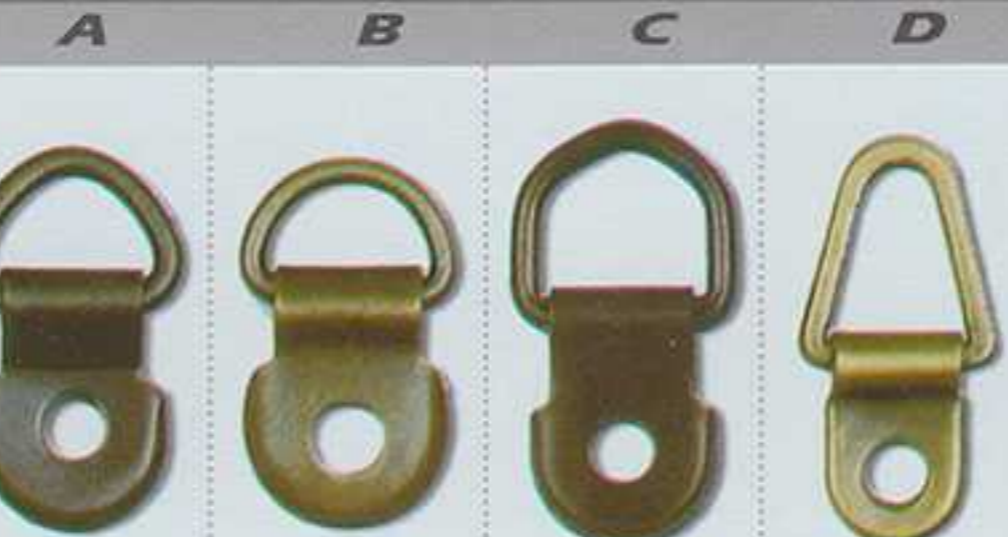

BT 69

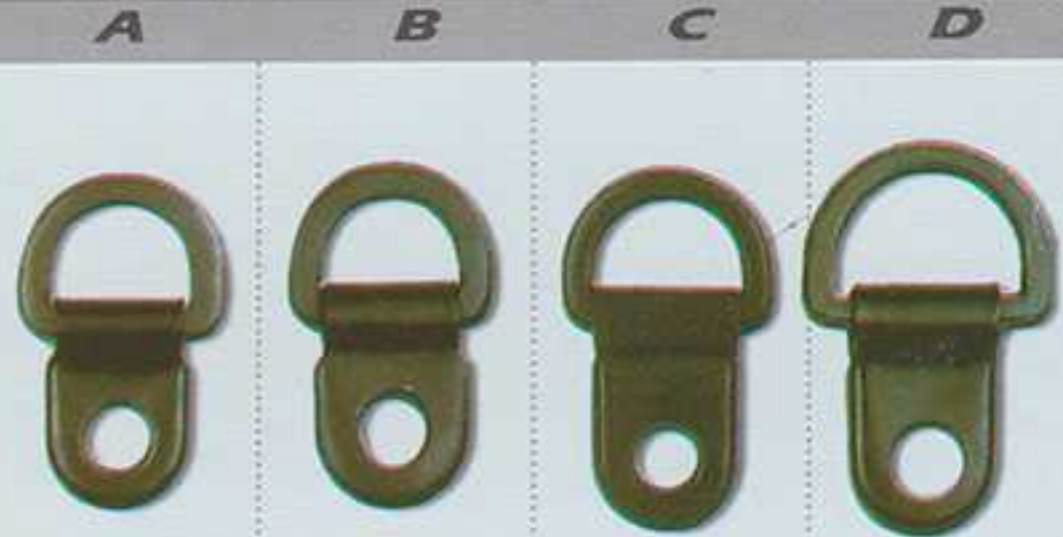

BT 70

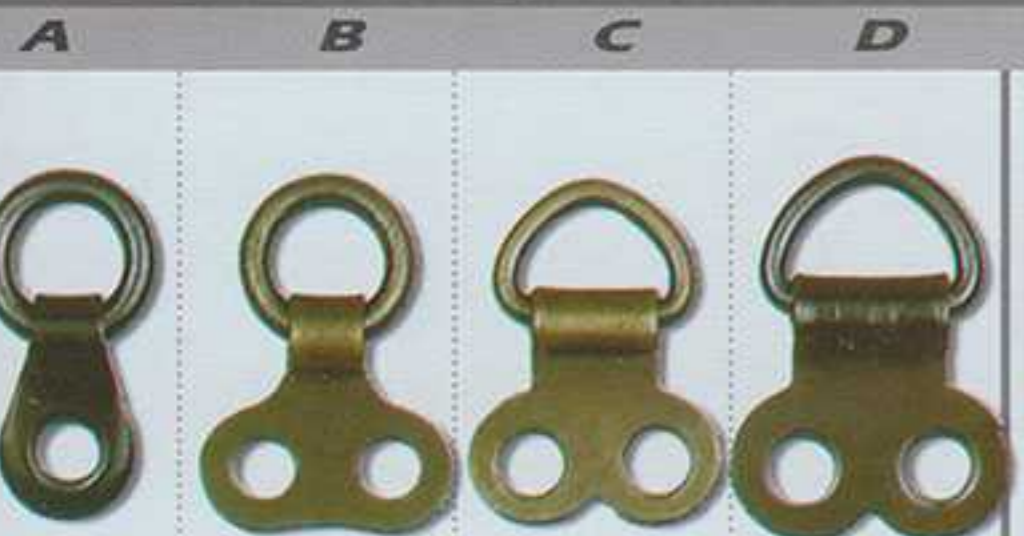

BT 71



BT 72



CV. Abadi Label

BT 73

A B C D



BT 74

A B C D



BT 75

A B C D



BT 76

A B C D



BT 77

A B C D



BT 78

A B C D



BT 79

A B C D



BT 80

A B C D

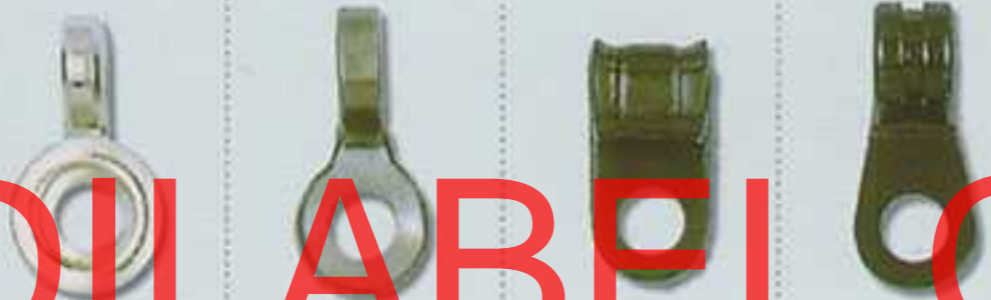

BT 81

A B C D



BT 82

A B C D



BT 83

A B C D



BT 84

A B C D



BT 85

A B C D



BT 86

A B C D



BT 87

A B C D



BT 88

A B C D



BT 89

A B C D



BT 90

A B C D



ABADILABEL.COM

CV. Abadi Label

BT 91

BT 92

BT 93

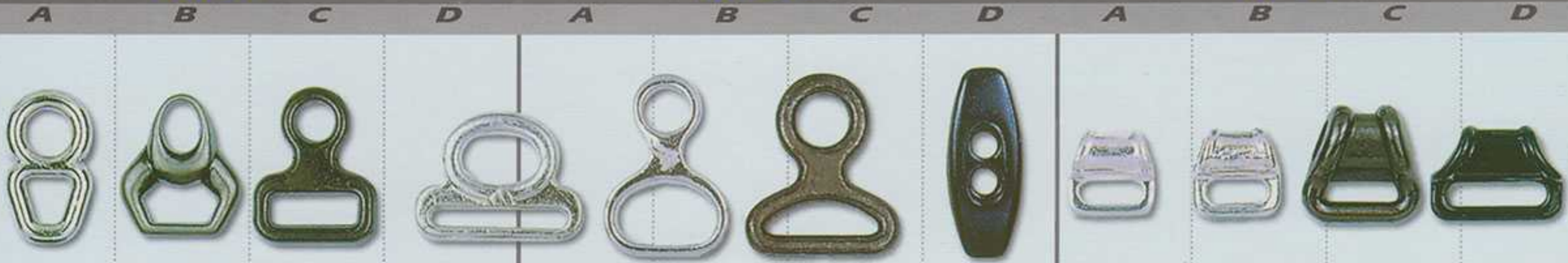

BT 94

BT 95

BT 96

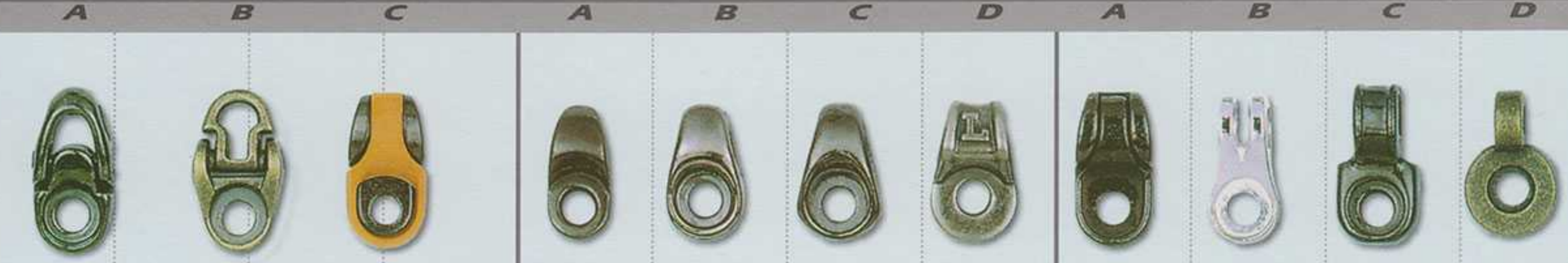

BT 97

BT 98

BT 99



BT 100

BT 101

BT 102

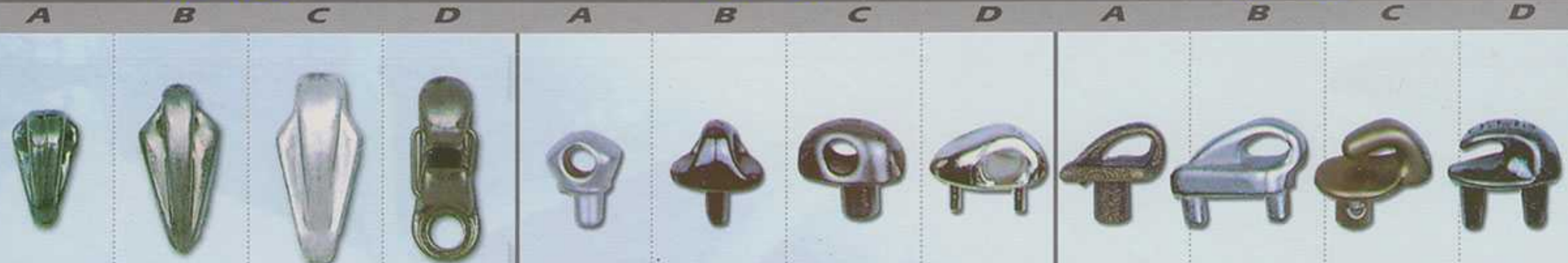

BT 103

BT 104

BT 105



BT 106

BT 107

BT 108

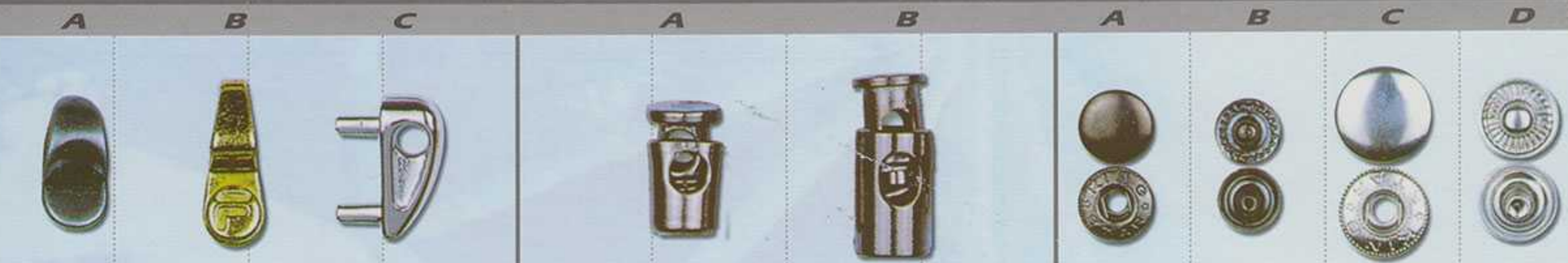

ABADILABEL.COM

CV. Abadi Label

BT 109



BT 110



BT 111



BT 112

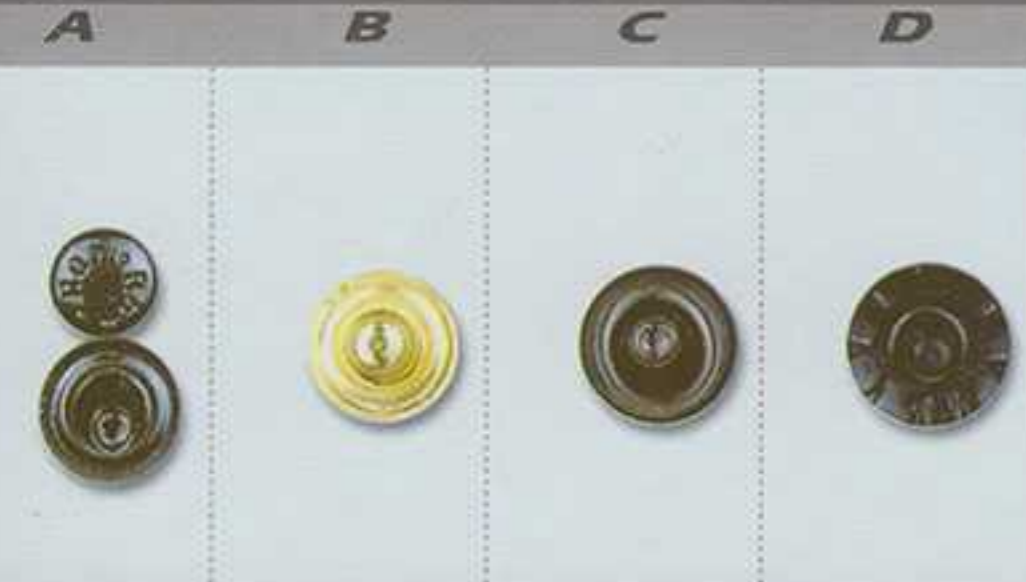

BT 113

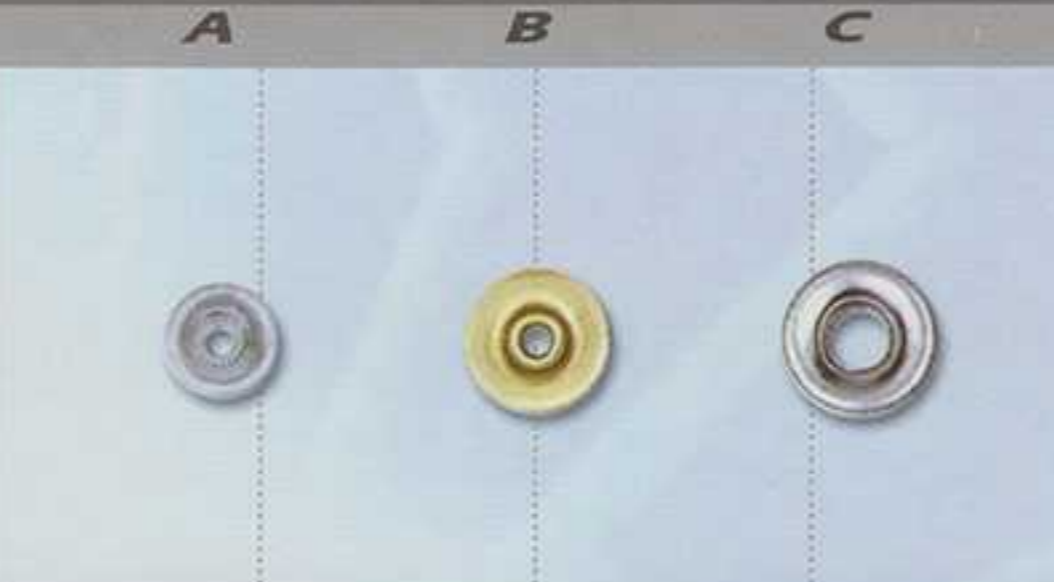

BT 114

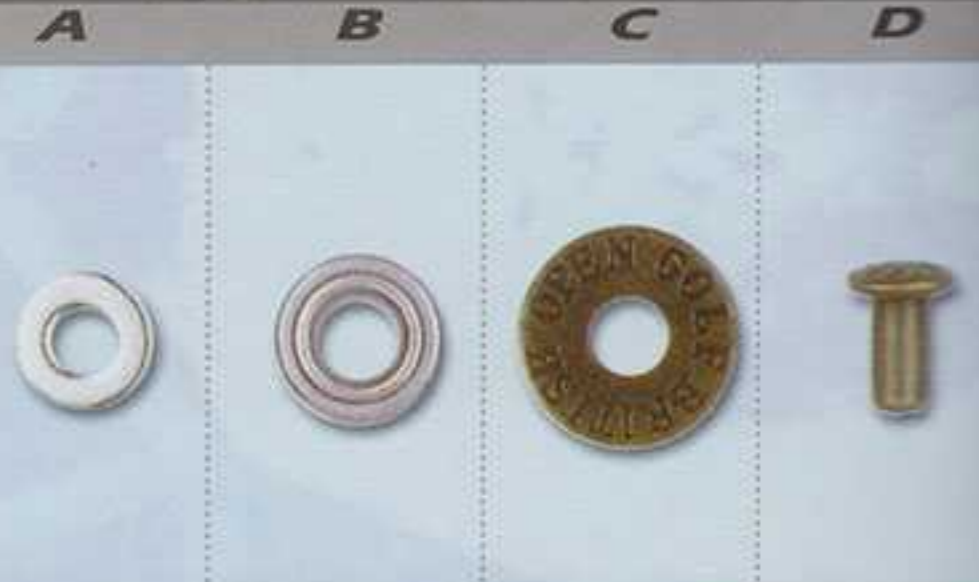

BT 115

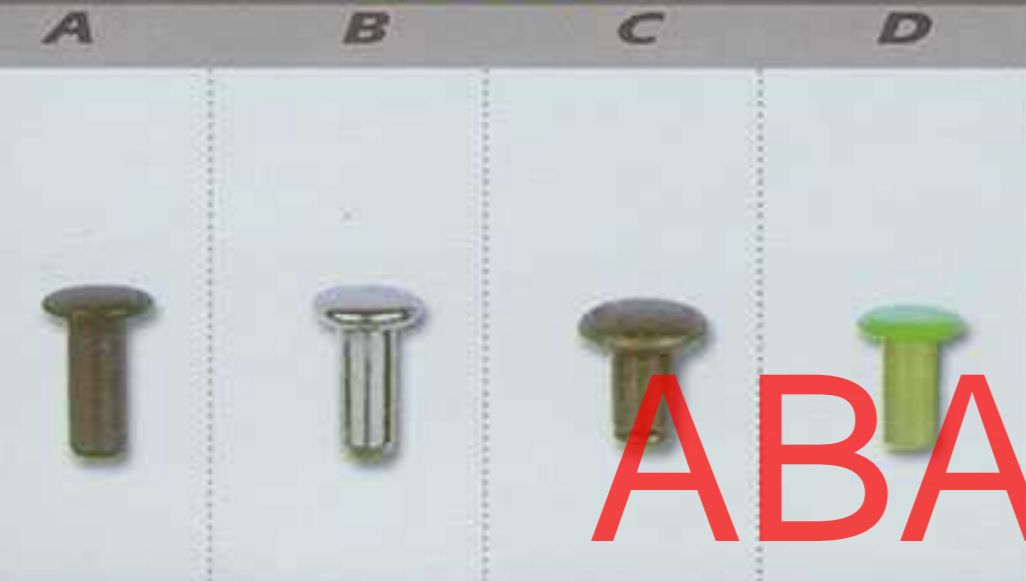

BT 116

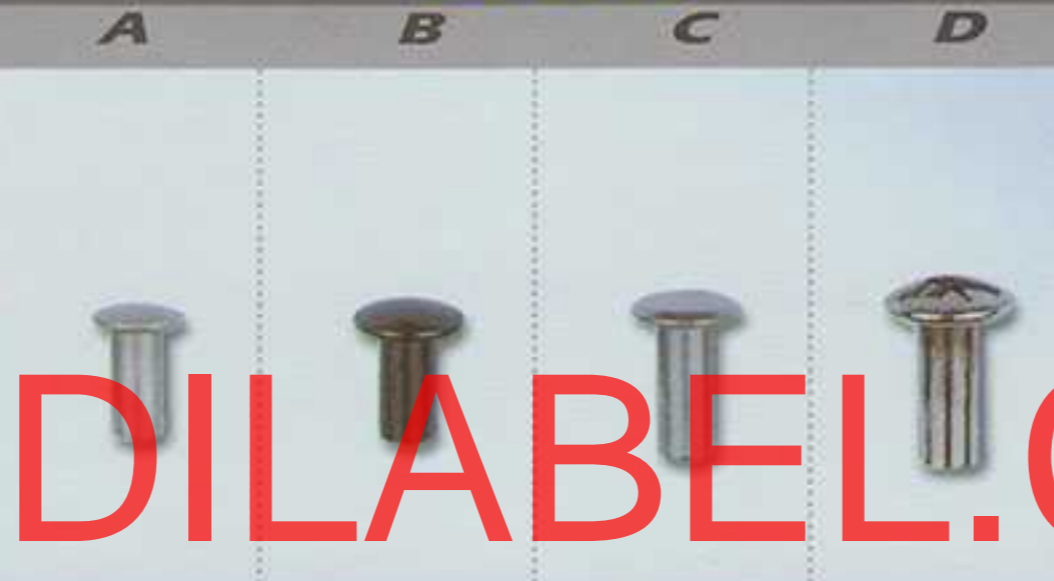

BT 117

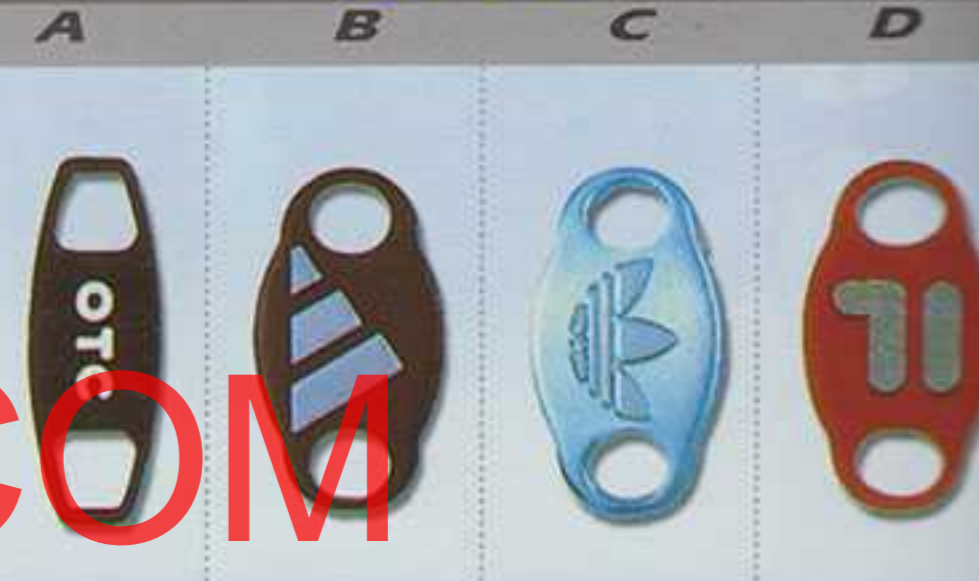

BT 118

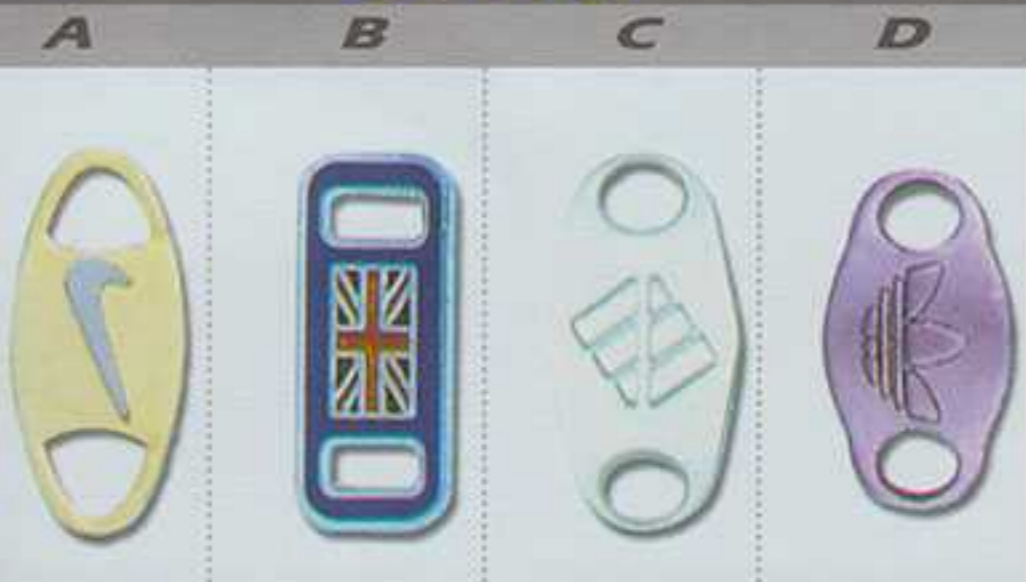

BT 119

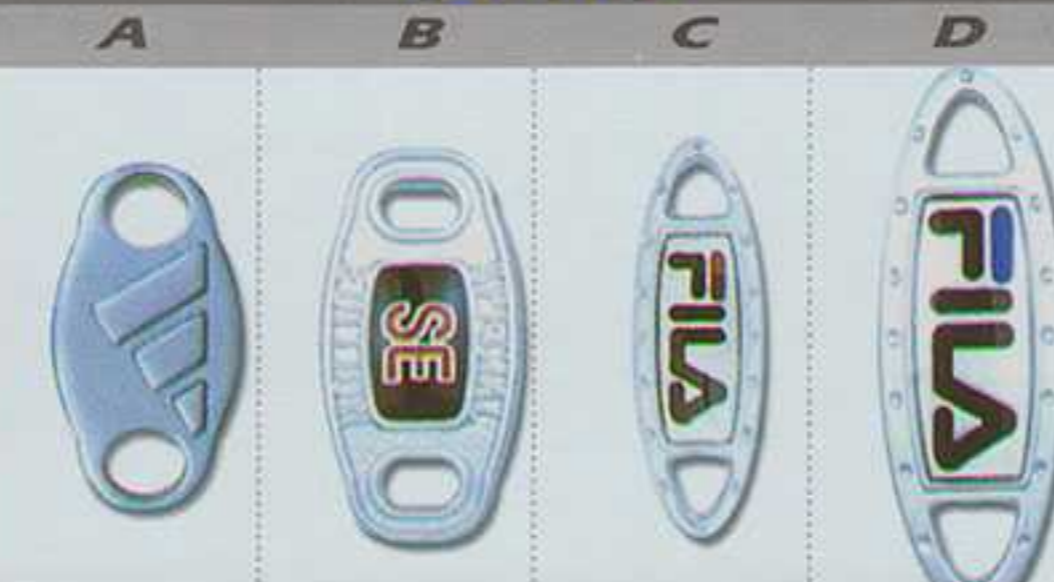

BT 120

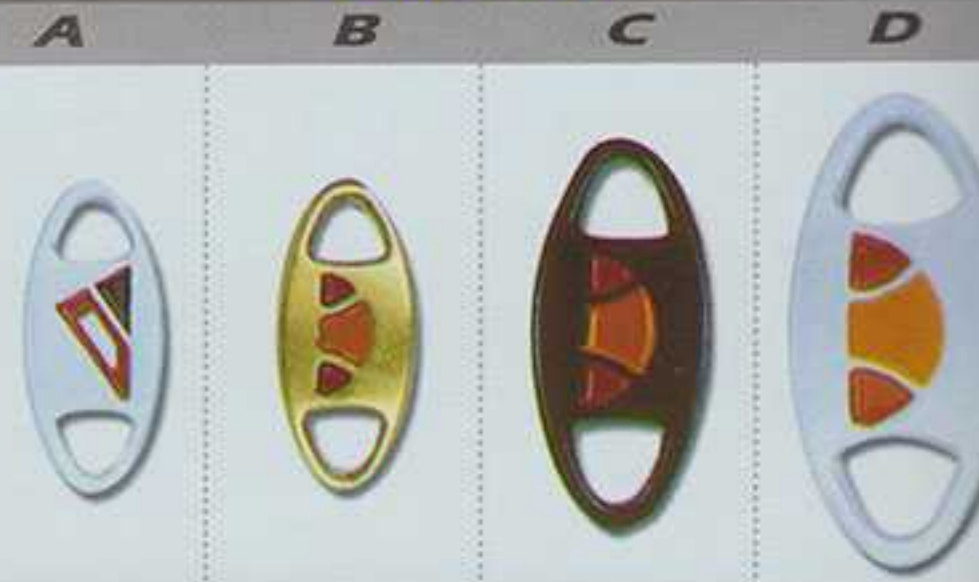

BT 121



BT 122



BT 123

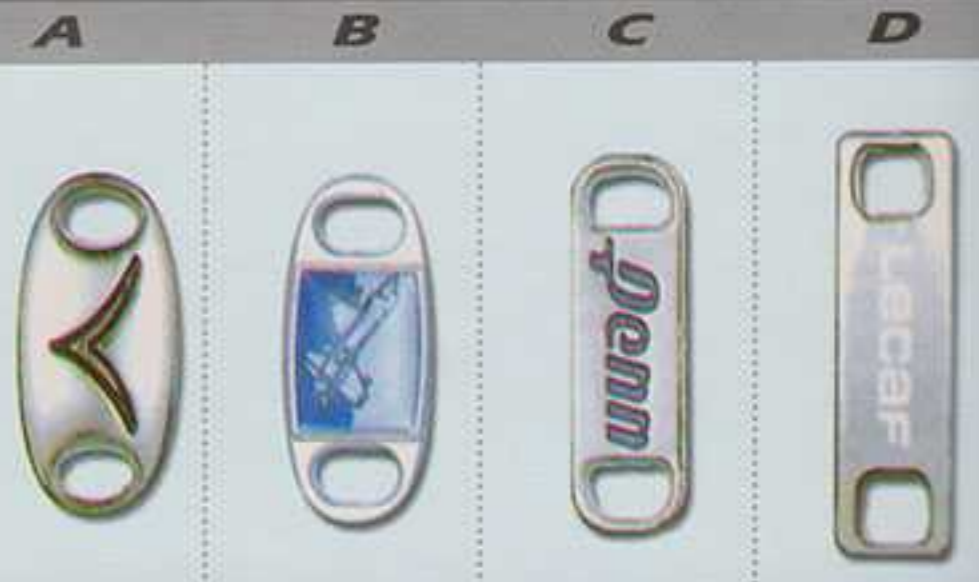

BT 124

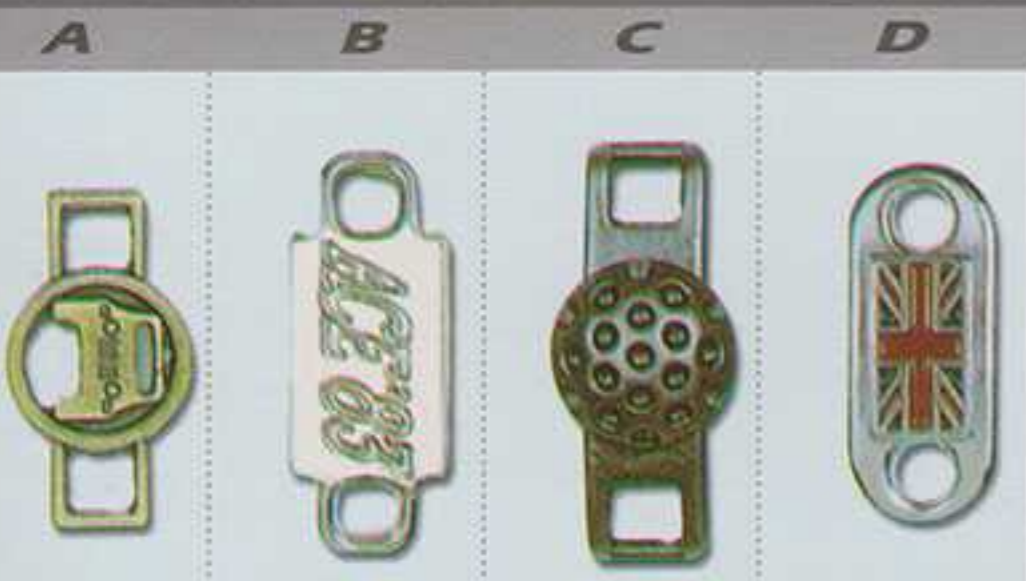

BT 125

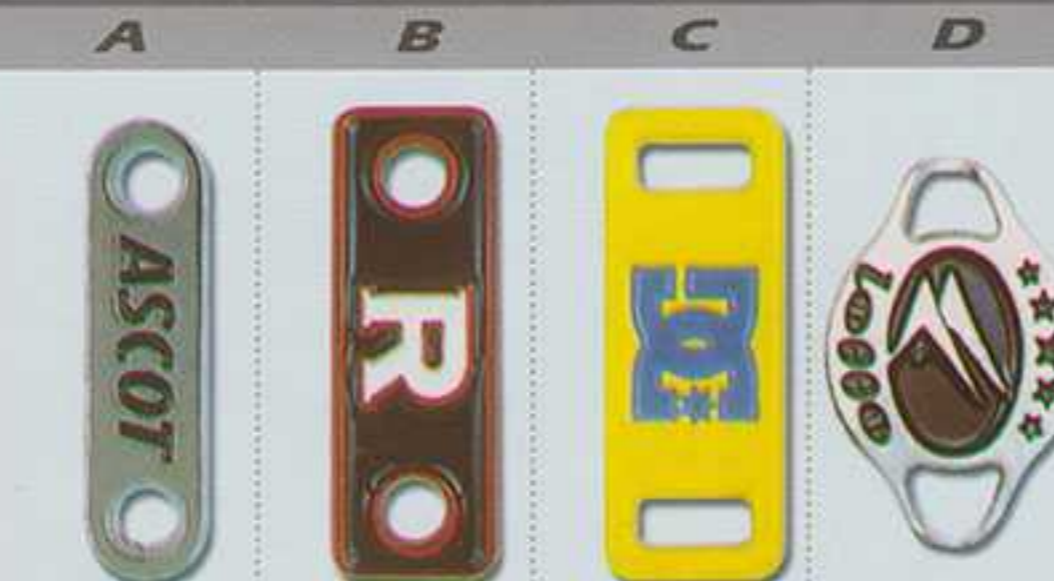

BT 126

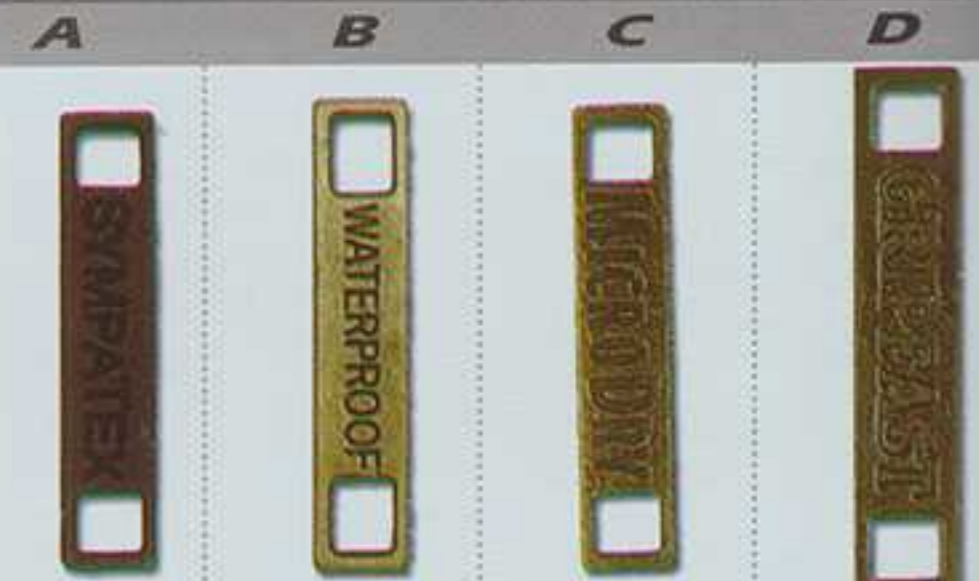

CV. Abadi Label

BT 127

BT 128

BT 129



BT 130

BT 131

BT 132

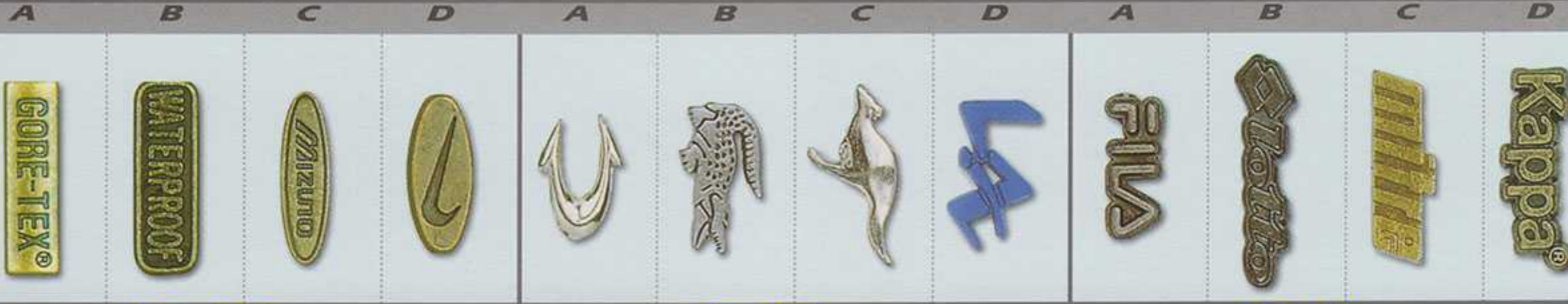

BT 133

BT 134

BT 135



BT 136

BT 137

BT 138

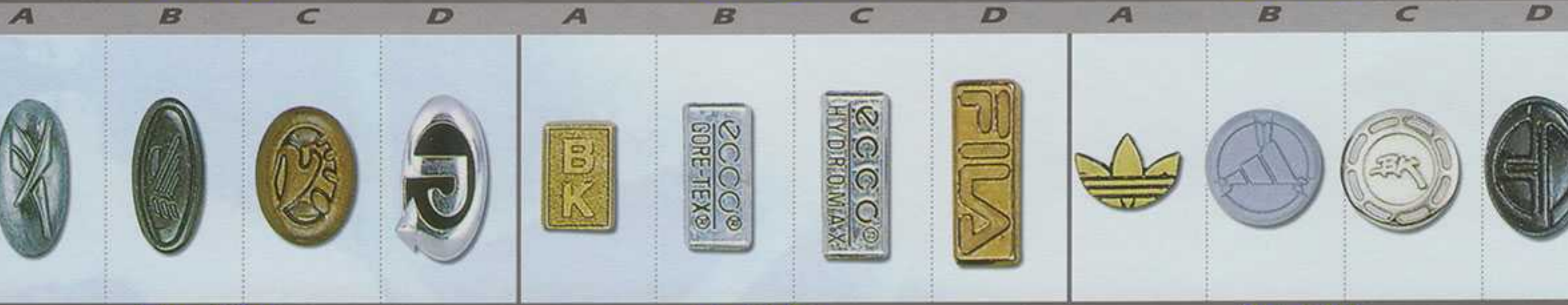

BT 139

BT 140

BT 141

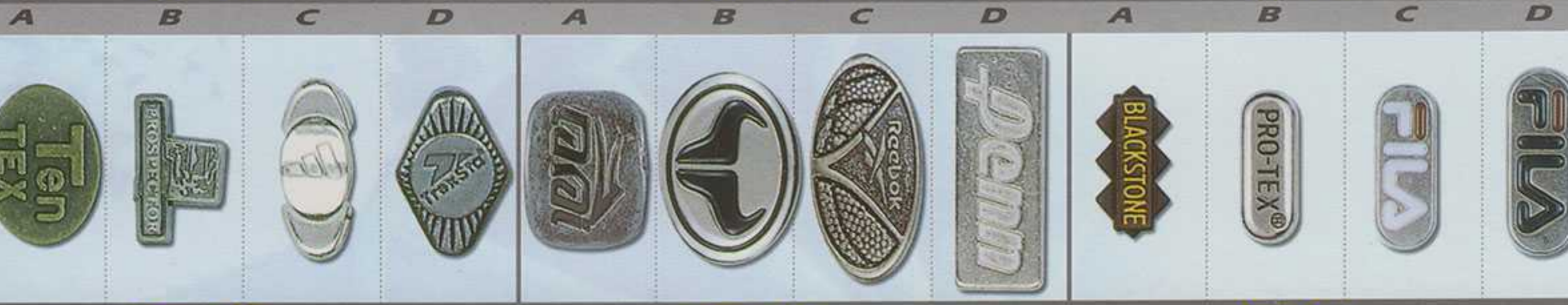

BT 142

BT 143

BT 144

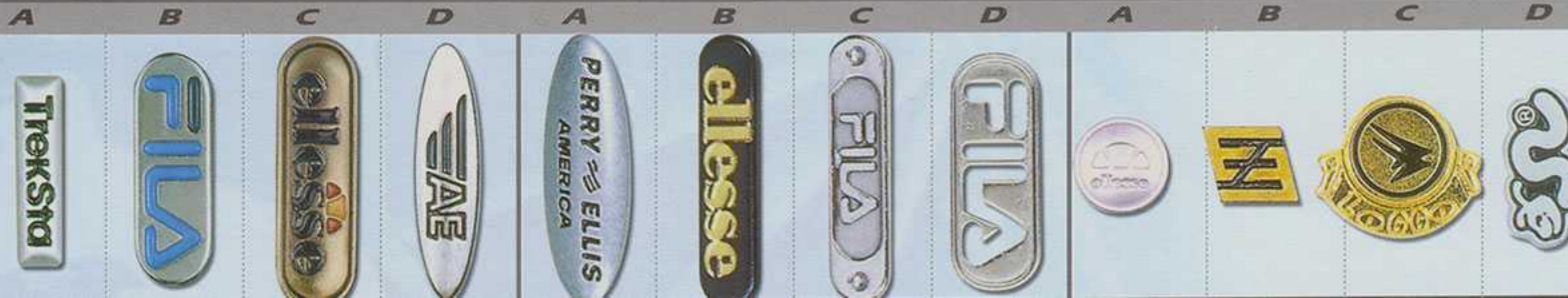

CV. Abadi Label

SIZE	PART"A"	PART"B"	PART"C"	PART"D"
17 mm x 13 mm				
17 mm x 14 mm				
17 mm x 15 mm				
15 mm x 13 mm				
15 mm x 14 mm				
15 mm x 15 mm				
15 mm x 13 mm				
13 mm x 13 mm				
RING SNAP				
17 mm x 13 mm				
17 mm x 15 mm				
15 mm x 15 mm				
15 mm x 13 mm				
13 mm x 13 mm				

- All Variant which as described, only as sample or reference
- Semua model yang tertera diatas, hanya sebagai referensi atau sample
- New fangled will be mode printing (Mold)
- Model baru, akan dibuatkan cetakan
- Colour module (Finishing) are adapted for order
- Modul dan warna (finishing) disesuaikan dengan pesanan.

CV. Abadi Label

BRASS



DIE CAST



PLASTIC



ENAMEL

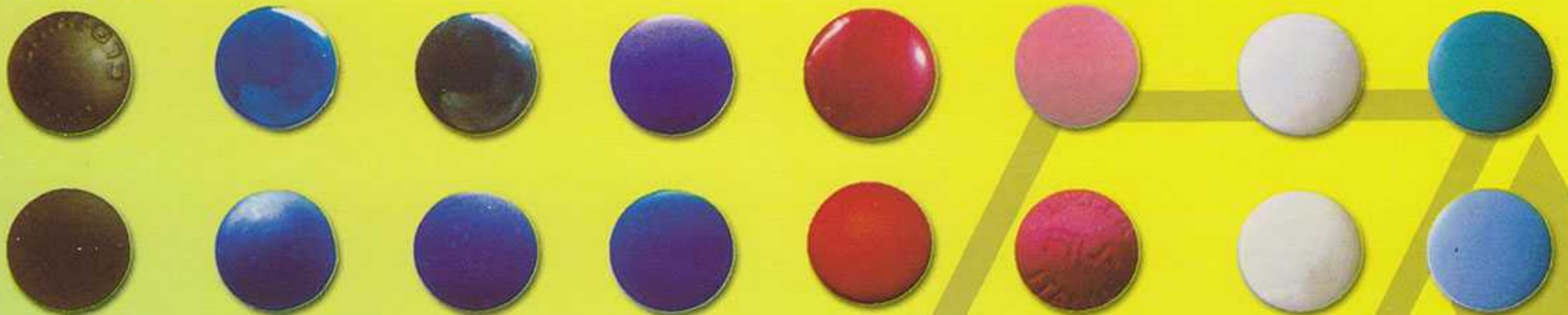

BABY SNAP



SBS.01 - 11m/m

SBS.02- 10m/m

SBS.03- 10m/m

- All Variant which as described, only as sample or reference
- Semua model yang tertera diatas, hanya sebagai referensi atau sample
- New fangled will be mode printing (Mold)
- Model baru, akan dibuatkan cetakan
- Colour module (Finishing) are adapted for order
- Modul dan warna (finishing) disesuaikan dengan pesanan.

ABADILABEL.COM

CV. Abadi Label

EYELET



RAM EYELET



OVAL EYELET



POLY WASHER



- All Variant which as described, only as sample or reference
- Semua model yang tertera diatas, hanya sebagai referensi atau sample
- New fangled will be mode printing (Mold)
- Model baru, akan dibuatkan cetakan
- Colour module (Finishing) are adapted for order
- Modul dan warna (finishing) disesuaikan dengan pesanan.

ABADILABEL.COM

CV. Abadi Label

TACK BUTTON



TBG 01



TBG 02



TBG 03



TBG 04



TBG 05



TBG 06



TBG 07



TBG 08



TBG 09



TBG 10



TBG 11



TBG 12



TBG 13



TBG 14



TBG 15



TBG 16



TBG 17



TBG 18



TBG 19



TBG 20



TBG 21



TBG 22



TBG 23



TBG 24



TBT 01



TBT 02



TBT 03



TBT 04



TBT 05



TBT 06



TBT 07



TBT 08



TBT 09



TBT 10



TBT 11



TBT 12



TBT 13



TBT 14



TBT 15



TBT 16



TBT 17



TBT 18



TBT 19



TBT 20



TBT 21



TBT 22



TBT 23



TBT 24

TBG



TBT



- All Variant which as described, only as sample or reference
- Semua model yang tertera diatas, hanya sebagai referensi atau sample
- New fangled will be mode printing (Mold)
- Model baru, akan dibuatkan cetakan
- Colour module (Finishing) are adapted for order
- Modul dan warna (finishing) disesuaikan dengan pesanan.

CV. Abadi Label



ABADILABEL.COM

Rivet

MONO									
	4 m/m	6 m/m	7 m/m	8 m/m	8x3,8x7 m/m	8x3,8x10 m/m	8x4x10 m/m	9 m/m	10 m/m
AUTO									
	8 m/m	9 m/m	9 m/m	9,5 m/m	9,5 m/m	9,5 m/m	9,5 m/m	9,5 m/m	9,5 m/m
RIVET JEAN'S STEEL									
	9 m/m	9,5 m/m	9,5 m/m	10 m/m	10 m/m	10 m/m	10 m/m	10 m/m	10 m/m
RIVET JEAN'S DIE CAST									
	8 m/m	9 m/m	9 m/m	11 m/m	11 m/m	11 m/m	11 m/m	11 m/m	11 m/m

- All Variant which as described, only as sample or reference
- Semua model yang tertera diatas, hanya sebagai referensi atau sample
- New fangled will be mode printing (Mold)
- Model baru, akan dibuatkan cetakan
- Colour module (Finishing) are adapted for order
- Modul dan warna (finishing) disesuaikan dengan pesanan.

CV. Abadi Label

Body Zipper Die Cast



SZ 01 - 10 m/m



SZ 02 - 8 m/m



SZ 03 - 5 m/m



SZ 04 - 3 m/m

Puller Die Cast



SP 01 - 44\17 m/m



SP 02 - 25\8.5 m/m



SP 03 - 20\09 m/m



SP 04 - 16\8.5 m/m



SP 05 - 35\11.5 m/m



SP 06 - 35\12 m/m



SP 07 - 33.5\10 m/m



SP 08 - 30\10.5 m/m



SP 09 - 34.5\12 m/m



SP 10 - 35\15 m/m



SP 11 - 38.5\11.5 m/m



SP 12 - 35\12 m/m



SP 13 - 22\12 m/m



SP 14 - 30\9.5 m/m



SP 15 - 33.5\10 m/m



SP 16 - 35\9 m/m



SP 17 - 36\13 m/m



SP 18 - 31.5\9 m/m



SP 19 - 32\7.5 m/m



SP 20 - 24.5\6 m/m



SP 21 - 21\6 m/m



SP 22 - 24\10.5 m/m



SP 23 - 42\12 m/m



SP 24 - 31\11 m/m



SP 25 - 32.5\8 m/m



SP 26 - 27.5\7 m/m



SP 27 - 25.5\16 m/m



SP 28 - 27\15 m/m

- All Variant which as described, only as sample or reference
- Semua model yang tertera diatas, hanya sebagai referensi atau sample
- New fangled will be mode printing (Mold)
- Model baru, akan dibuatkan cetakan
- Colour module (Finishing) are adapted for order
- Modul dan warna (finishing) disesuaikan dengan pesanan.

CV. Abadi Label



SP 29
34.5\20 m/m



SP 30
30\19.5 m/m



SP 31
22\14 m/m



SP 32
21.5\14 m/m



SP 33
30.5\18 m/m



SP 34
27\13.5 m/m



SP 35
22\12 m/m



SP 36
30\20 m/m



SP 37
29\24 m/m



SP 38
21\16.5 m/m



SP 39
22\21.5 m/m



SP 40
21.5\18 m/m



SP 41
40\9 m/m



SP 42
42.5\13 m/m



SP 43
32\12 m/m



SP 44
27\10 m/m



SP 45
29\14.5 m/m



SP 46
28.5\14.5 m/m



SP 47
31\11 m/m



SP 48
23\10 m/m

ABADILABEL.COM



SP 49
24\14 m/m



SP 50
28\21.5 m/m



SP 51
32.5\23 m/m



SP 52
30.5\16.5 m/m



SP 53
34\13 m/m



SP 54
38.5\7 m/m



SP 55
30.5\19.5 m/m



SP 56
39.5\9 m/m



SP 57
31\20 m/m



SP 58
22\21 m/m



SP 59
21.5\11.5 m/m



SP 60
20\14.5 m/m



SP 61
35\17.5 m/m



SP 62
20\5 m/m



SP 63
18\7 m/m



SP 64
23\6 m/m

- All Variant which as described, only as sample or reference
- Semua model yang tertera diatas, hanya sebagai referensi atau sample
- New fangled will be mode printing (Mold)
- Model baru, akan dibuatkan cetakan
- Colour module (Finishing) are adapted for order
- Modul dan warna (finishing) disesuaikan dengan pesanan.

CV. Abadi Label

Hole Button (H2) Die Cast



SH : 01
Ø 22,5 m/m



SH : 02
Ø 15 m/m



SH : 03
Ø 18 m/m



SH : 04
Ø 15 m/m



SH : 05
Ø 15 m/m



SH : 06
Ø 12 m/m



SH : 07
Ø 13 m/m

Hole Button (H4) Die Cast



SH : 08
Ø 17 m/m



SH : 09
Ø 15 m/m



SH : 10
Ø 13 m/m



SH : 11
Ø 15 m/m



SH : 12
Ø 13 m/m



SH : 13
Ø 12,5 m/m



SH : 14
Ø 13 m/m

Snap Button Die Cast



SSN : 001
Ø 17 m/m



SSN : 002
Ø 17 m/m



SSN : 003
Ø 17 m/m



SSN : 004
Ø 17 m/m



SSN : 005
Ø 15 m/m



SSN : 006
Ø 12 m/m



SSN : 007
Ø 12 m/m

O Ring Die Cast



SR : 10
Ø 33 m/m



SR : 11
Ø 29,5 m/m



SR : 12
Ø 25 m/m



SR : 13
Ø 19 m/m

Prisma Ring Die Cast



SR : 14-41 m/m



SR : 15-40 m/m



SR : 16-29 m/m



SR : 17-25 m/m



SR : 18-21 m/m



SR : 19-20 m/m

- All Variant which as described, only as sample or reference
- Semua model yang tertera diatas, hanya sebagai referensi atau sample
- New fangled will be mode printing (Mold)
- Model baru, akan dibuatkan cetakan
- Colour module (Finishing) are adapted for order
- Modul dan warna (finishing) disesuaikan dengan pesanan.

Eyelet & Washer

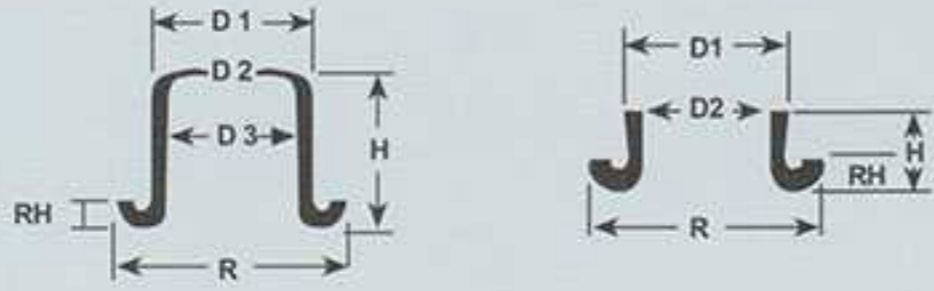

Material

Aluminium, Brass, Iron

(S)(#2)	R	D1	D2	D3	RH	H	R	D1	D2	RH
100#	6. ⁵	4. ²	3. ¹	3. ⁵	0. ⁶	Requested	7. ⁸	4. ⁷	4. ²	0. ⁵
200#	7. ⁸	4. ⁵	3. ²	3. ⁸	0. ⁸	"	8. ⁰	5. ⁴	4. ⁷	0. ⁵
250#	8. ⁵	4. ⁵	3. ²	3. ⁸	0. ⁸	"	8. ⁵	5. ⁴	4. ⁷	0. ⁵
300#	9. ⁰	5. ³	4. ⁰	4. ⁶	0. ⁹	"	9. ⁵	6. ²	5. ⁵	0. ⁶
350#	10. ⁰	5. ⁷	4. ³	5. ⁰	0. ⁹	"	10. ⁰	6. ⁵	5. ⁸	0. ⁶
400#	10. ⁵	6. ⁰	4. ⁵	5. ³	1. ⁵	"	10. ⁵	6. ⁹	6. ²	0. ⁶
500#	11. ⁵	6. ⁰	4. ⁵	5. ³	1. ⁵	"	10. ⁵	6. ⁹	6. ²	0. ⁶

※The height can be minimally modified by your order and inquiry

Oval Eyelet & Washer

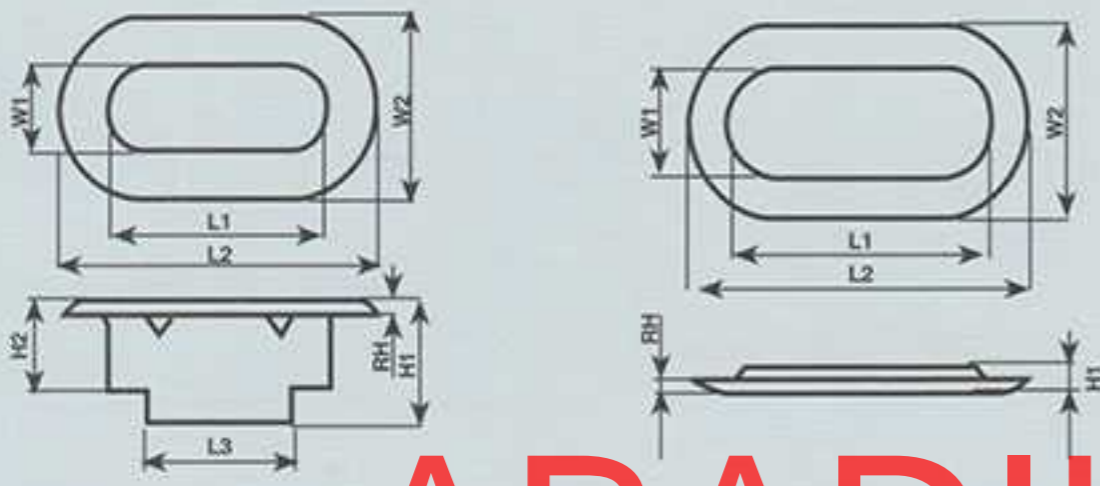

Material

Aluminium, Brass

Current Size Base on Inside

7, 8, 9, 10, 13, 16, 18, 19, 21, 23, 25, 29, 35, 48, 56 mm

ABADILABEL.COM

D-Ring & Hook



For Hand Machine

For Automatic Machine

For Hand Machine

For Automatic Machine

Material

Brass, Steel, Zinc

Ring And Hook Should Be Safe And Strong

Buckle

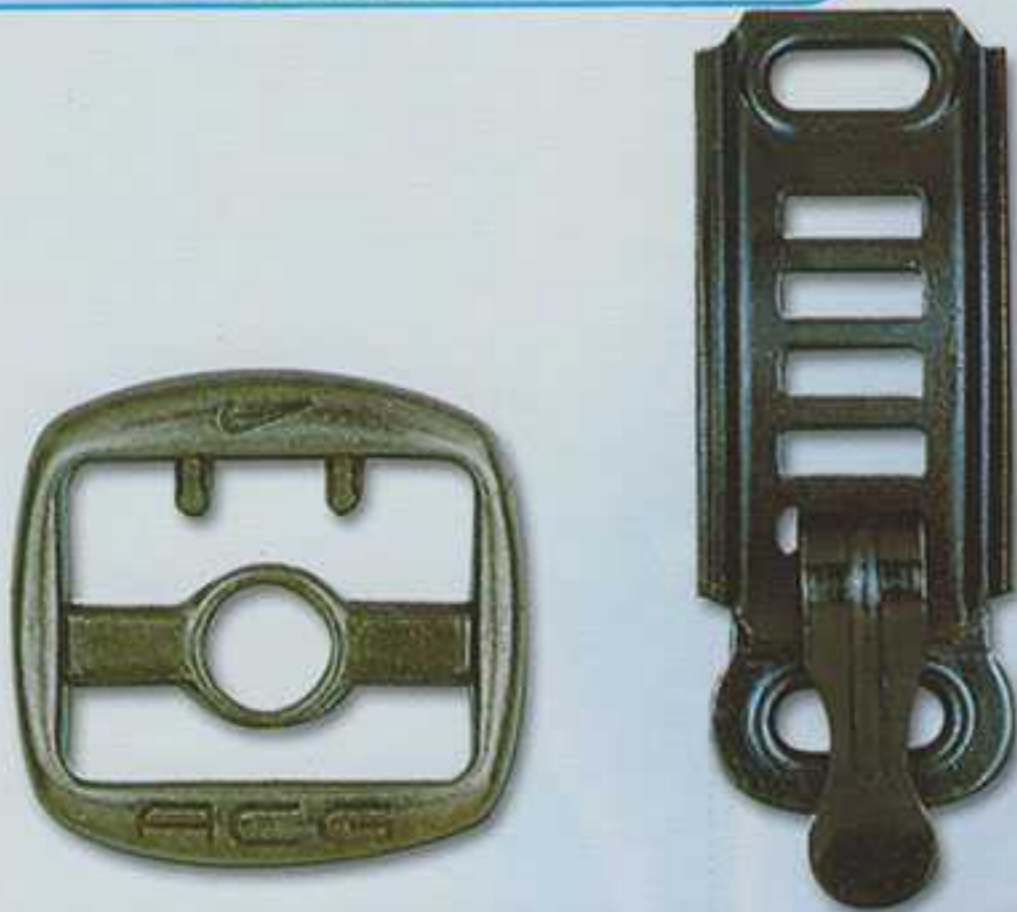

Material

Brass, Steel, Zinc

Design of high class, Smartness of Shapely.
Even when used for long time, it is nor separated nor
abraded, and plated coating is not well peeled off

Spike



Special Material

Steel

The spike buckle to prevent sliding is made by
special low material and design.
Specially it's for snow or ice

Setting Machine and Tools

Picture	Model	Setting products
	<p>Auto setting m/c for "SPEED LACE" Speed lace : Automatically supplied Washer : Not automatically supplied but possible by hand - supply</p>	
	<p>Auto setting m/c for "HOOK" Hook : Automatically supplied Washer : Not automatically supplied but possible by hand-supply</p>	
	<p>Manual setting m/c. Changing tool part can set all items</p>	
	<p>Auto setting m/c for Solid tube rivet Cab rivet</p>	
	<p>Auto setting m/c for "EYELET" Eyelet and washer supplied automatically.</p>	
	<p>Setting tool for machines. (Suitable for m/c use.)</p>	
	<p>Manual setting tool for small q' ty setting in developing room. Changing tool parts can set all items</p>	

ABADILABEL.COM